

M115  
Rev. A  
Type S Flowmeters:  
1½" & 2" with 800 Series Registers



## Operating and Maintenance Manual for Type S Flowmeters



## TABLE OF CONTENTS

Installation .....	1
Operation .....	3
Printer Models .....	3
Calibration .....	4
Maintenance .....	5
Register .....	5
Preset Valve .....	7
Measuring Chamber .....	11
Stuffing Box .....	15
General Maintenance .....	16
TroubleShooting Guide .....	18
Dimensions .....	20

## 1 1/2" & 2" TYPE "S" FLOWMETERS WITH 800 SERIES REGISTERS AND 2" PRESET VALVE

The Preset Valve is provided either with a Double Trip Mechanism, or a Single Trip Mechanism, depending upon the flow rate and viscosity of the liquid to be metered.

The Double Trip Valve may be used for liquids having viscosities less than 10,000 S.S.U. (i.e., water, gasoline, etc.). Use of the Double Trip Valve will be determined by the need to reduce shock pressure in the line, which may result either from high operating pressure or high rates of flow. A fine mesh strainer should be used to protect the Preset Valve piston and cylinder as well as to protect the measuring element in the flowmeter.

Single Trip Valves may be used for viscosities greater than 10,000 S.S.U., or when liquids, such as water, solvents, gasoline, etc., are operated at low rates of flow in gravity type installations.

If not certain of the suitability of the valve to the characteristics of the liquid, contact your nearest authorized Actaris Neptune distributor. A good rule of thumb, use double-trip valves if flow rate is greater than 50 gallons a minute and the viscosity is less than 10,000 S.S.U.

## INSTALLATION

Instructions for installation and testing of Actaris Neptune Type S Flowmeters are contained in this manual. Should more detailed information and further assistance be necessary, do not hesitate to contact the representative from whom you purchased the flowmeter, or Actaris Neptune.

### Strainer

Plan the installation in such a way as to allow the strainer to be coupled directly to the inlet of the flowmeter. Where this is not possible, any piping between these units should be thoroughly cleaned out.

Be careful to allow room for easy removal of the strainer basket.

### Air/Air Release

Air releases are not supplied for all liquids, but when an air release valve is used, it should be installed in a position as close as possible to the inlet of the flowmeter. This will ensure the removal of the greatest possible amount of air from the liquid before metering.

### Piping

Use pipe cement on male threads only.

The piping on the outlet side of the flowmeter should rise above the height of the flowmeter in order to form a natural trap. This arrangement is necessary to eliminate the possibility of draining the measuring chamber. Where this is not possible, an anti-drain valve may be used.

Experience has shown the need for a valved bypass connection to be installed around the flowmeter. This arrangement permits product flow in the event that the flowmeter must be removed for repair.

## 1 1/2" & 2" TYPE "S" FLOWMETER WITH 800 SERIES REGISTERS AND 2" PRESET VALVE

## INSTALLATION

### Before Installing The Flowmeter

### Piping

Where an air release valve is used, the vent pipe should be 3/4" inside diameter pipe or tubing. Care should be taken to prevent any possible obstruction to the free flow of air in this line. This line should be connected to a drip collecting drum or back to storage. Do not vent to atmosphere.

The connecting piping should be firmly secured to prevent strain on the flowmeter casing. Provide for expansion or contraction of long runs of piping due to temperature changes, with self aligning couplings, or expansion joints.

**All piping on the inlet side of the flowmeter should be thoroughly cleaned out. Whenever possible, place a spool in the place of the flowmeter and flush out all lines thoroughly before the flowmeter is installed. The majority of service calls on new installations are eliminated by following these directions.**

Inlet and outlet are clearly marked; do not install backwards.

The connection to the outlet of the valve must be removable (or sufficiently flexible) to permit 2" axial movement in order for the valve to be removed from the flowmeter for servicing.

To change the direction in which the register will face with respect to the pipe. (See page 6).

Open line valves slowly, allowing liquid to gradually enter flowmeter. (Use care not to overspeed the flowmeter).

Pass sufficient liquid to clear the lines of air. Check the rate of flow. It should not exceed the rated capacity of the flowmeter.

Set the bypass of the pump so that the maximum pressure at no time exceeds 125 psi. When the installation is completed, check that the shock pressure (the pressure as the shut-off or Preset Valve is closed) at the flowmeter does not exceed 125 psi. The pressure may be checked by installing a pressure gauge at the inlet of the flowmeter. Do not try to increase the flow through undersize pipes and fittings by means of excessive pressures, as this will result in leaking gaskets and collapsed air release floats when air release equipment is used.

Temperature of the liquid should not exceed that specified for the flowmeter.

Test the flowmeter as per instructions on page 4. All flowmeters are carefully calibrated and tested at the factory, and no adjustment should be necessary. Instructions for correcting the calibration, if the registration appears to be inaccurate, are contained on page 4.

When the installation is still new, the strainer should be cleaned very frequently. After the system has had a chance to be thoroughly washed out, only periodic cleaning is necessary.

## Air Vent Line

## When Installing Flowmeter

## After Installing

## Cleaning The Strainer

## OPERATION

1. Reset the register to zero by turning reset knob to the rear stop. On Printer models, first insert ticket. (See below).
2. Set the Preset wheels to the desired quantity.
3. Start pump - Open Preset Valve and make delivery.
4. After completing delivery on Printer models, stamp final reading on ticket by turning operating knob to the front stop and remove ticket.

Pushing the red emergency stop button will trip the valve. After it has been used either the delivery may be completed automatically as originally set by re-opening the valve or the mechanism may be set for a new figure. The accuracy of delivery in either case is not affected.

## PRINTER MODELS

To insert a ticket be sure that the operating knob is turned to its forward stop. Then depress the Dust Bar and insert the ticket in the ticket slot under it "face-down, bottom end first" as noted on the instruction plate. Turn the operating knob to its rear stop. This resets the visible wheels to zero, locks the ticket in place, and prints the initial reading on the ticket.

It is now impossible to remove the ticket without tearing it.

Upon completion of delivery, turn the operating knob to its forward stop. This operation prints the final reading and releases the ticket.

The Printer Registers are shipped from the factory with the ticket guides properly adjusted. If for any reason it is necessary to reposition the ticket, proceed as follows:

1. Remove top cover of register.
2. Insert a ticket into the printer. Loosen the clamp screws on the rear of the ticket guides. Move the guides to the right or left as required. Tighten clamp screws. The ticket must slide freely between the guides. If the ticket binds at the forward end of the guide, remove the guide and rebend the tail.

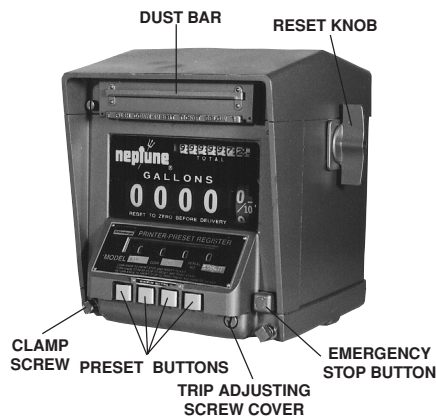

**FIGURE 1**  
**PRESET 800 SERIES PRINTER REGISTER**

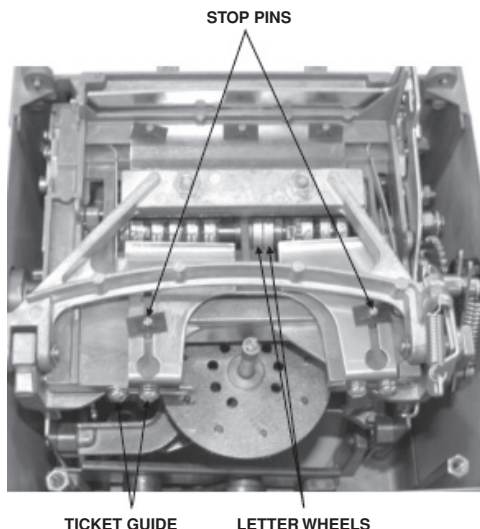

**FIGURE 2**  
**PRINT UNIT ADJUSTMENTS**

## OPERATION

### To Operate The Flowmeter

### Emergency Stop

## PRINTER MODELS

### To Insert And Remove Tickets

### To Adjust Ticket Guides

3. If it is necessary to raise or lower the printing, push the two stop pins to the front or rear with the end of a screw driver.
4. Replace the top cover.

## CALIBRATION

Test 1½" and 2" flowmeters with a volumetric prover large enough to accept at least one-minute's flow. If the Preset mechanism does not trip correctly, see instructions on page 10, "To Adjust the Tripping Point."

When testing flowmeters having registers reading in pounds the testing should be done with reliable scales which will hold from 600 to 1000 pounds of product plus the container.

It is advisable to calibrate all flowmeters measuring viscous liquids by weight since it is difficult to properly drain these liquids from volumetric type test measures.

Erratic registration is an indication of trouble in the system, usually caused by air or dirt in the measuring chamber. Do not try to correct this by calibration of the flowmeter, but first check over the piping for air leaks, clean the strainer and then, if the trouble has not been found, clean the flowmeter as directed on pages 11 and 12. If this does not correct the trouble, check for faulty installation.

Over-registration is an indication of air, whereas under-registration is generally caused by dirt or pipe scale in the measuring chamber, or the liquid by-passing the flowmeter in some manner, or damaged internal mechanism.

When the flowmeter registers consistently either more or less than is delivered, the calibration may be corrected in the following manner:

1. Remove four screws holding top cover and remove cover of the register.
2. Lift and turn the Change Gear Shifter (see Figure 3) (Note: Does not apply to all registers) in the direction indicated on the top of the shifter.

3. A series of holes in the plate, marked A to H, engage a guide pin at different settings. Altering the setting by one hole changes the calibration approximately 0.15%. Registers equipped with a cadmium-plated shifter have a wider range of adjustment. With a shifter so identified, changing the setting one hole, changes the registration 0.5%. Such shifters will normally be found only in new registers that read in Pounds or Kilograms. These registers have an "S" stamped in front of the model number.

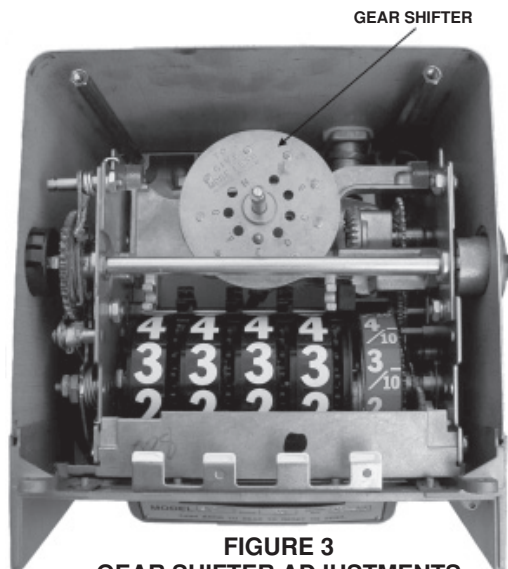

**FIGURE 3**  
**GEAR SHIFTER ADJUSTMENTS**  
(Does not apply to all registers)

## CALIBRATION

### Flowmeter Reading In Gallons

### Flowmeter Reading In Pounds

## ERRATIC REGISTRATION

### Consistent Over- Or Under-Registration

When a register equipped with the plated shifter replaces one that is not plated, the change gears must be adjusted downward by approximately 3<sup>1</sup>/<sub>2</sub>%. For this reason, replace existing change gears with new gears in accordance with Form TSG-310.

After changing the calibration always replace top cover; making sure that the sheet steel housing on the sides and back fits into the groove in the bottom edge of cover. Run a small amount of liquid through the flowmeter before testing. This operation must be performed to ensure that all backlash in the gearing has been removed. When this has been done, retest the flowmeter as outlined in section entitled "Calibration." In order to prevent tampering, always reseal the register after calibration is completed.

**Note:** For broader change gear requirements and calibration adjustment refer to Form TSG-310.

## MAINTENANCE

### REGISTER

Only minor field repair of register parts is recommended. When a register is in need of repair of service other than that for which instruction is given here, it should be returned to the nearest authorized Actaris Neptune distributor.

Disconnect valve linkage at valve end. (Cotter pin, washer, and clevis pin must be removed before hand.) Loosen the two clamp screws on lower front of the register. Lift register off flowmeter.

When one register is removed and another substituted, (1) Check the number of teeth on the Change Gears (see Figure 4). They must be the same as the gears on the old register **and on the same respective spindles**. The number of teeth is stamped on each gear. To remove these gears, close the split end of the spindle with a pair of pliers and pull off the gear. After putting on a gear, spread the end of the spindle slightly. (2) Make sure that the position of the Change Gear Shifter is the same on the new register as the old one. Each hole is lettered for convenience.

**Note:** Type S meters supplied since 1990 do not utilize the gear shifter mechanism.

Register mask are made of plastic and require special treatment. Instructions for cleaning are given below:

If the mask becomes soiled with grease and oil, solvents for these substances, such as kerosene or naphtha, may be used to remove dirt. However, sprays that are commonly employed in cleaning glass windshields must not be used as cleaners, since they may contain solvents for the mask.

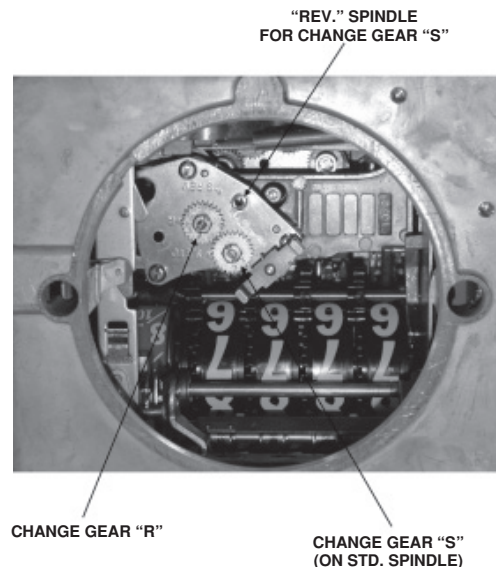

**FIGURE 4**  
**CHANGE GEAR ARRANGEMENT**

## MAINTENANCE

### REGISTER

#### Repair of Register

#### To Remove Register From Flowmeter

#### To Clean Register Mask

A water solution of nonabrasive soap is recommended for washing grease, oil, or dirt from the mask. It is then cleansed by rubbing gently with a soft cloth, in a manner similar to cleaning window glass, rinsing the mask in clean water, and finally drying.

Scouring cleanser and similar material must not be used in cleaning the mask, since they contain abrasives that scratch the surface.

The use of solvents, such as acetone, ethyl acetate, benzene, and ethylene dichloride, to brighten the surface of the mask is never recommended since these substances soften the surface of the plastic.

In determining whether the metering unit is a Right Hand or Left Hand Assembly, the position of the outlet of the flowmeter, as the operator faces the front of the register, is the governing factor. When facing the register, normal flow (Right Hand Assembly) is from left to right.

When the flowmeter is assembled as a Left hand assembly and it is desired to change it to a Right Hand assembly, or vice versa, proceed as follows:

1. Remove clevis pin (e) from valve linkage.
2. Unscrew the outside register link lock nut (p) and remove connecting rod (g) and clevis (f) as a unit.
3. Remove register link (n), rotate 1/2 turn and reassemble onto register as described in appropriate valve adjustment instructions. (Pages 7-8).
4. Loosen two clamp screws on lower front of register, lift register up and turn register 180°.

5. Remove operating shaft cap screw (c) on both sides.

6. Interchange connecting rod arm (h) and valve operating handle (a). The connecting rod arm must be assembled with notches (j and k) in specific relationship. (See item 3 of valve adjustment instructions for details regarding position of notches.)

7. Reassemble operating shaft cap screws (c).

8. Remove valve handle stop set screw (b) and screw into hole on opposite side of valve.

After completing the above instructions, the valve linkage must be adjusted in accordance with the procedure, for the specific type valve (i.e., Double Trip or Single Trip) as outlined on pages 7-8.

## To Change Position Of The Register

VIEW LOOKING AT BACK OF REGISTER

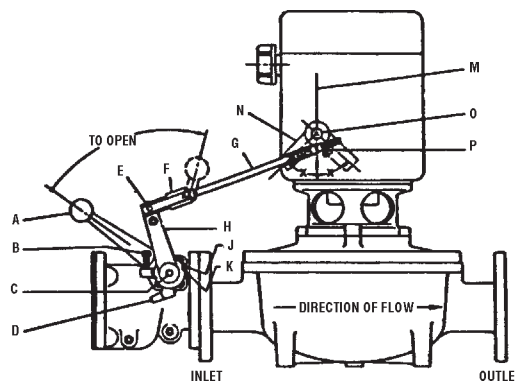

FIGURE 5  
LEFT HAND ASSEMBLY



## PRESET VALVE

**Note:** Before any adjustment of the Double Trip or Single Trip Preset Valve is made, be sure that the Preset setting wheels indicate a quantity, other than zero, to insure that the trip mechanism of the register is in proper position.

### To Adjust Double Trip Valve Linkage With Valve At Outlet Of Flowmeter

1. Depress the emergency stop button on the register and turn the shaft (o) clockwise.
2. Assemble register arm (n) on knurled knob in position as shown for specific assembly. (See Figure 6). Arm should move an equal distance each side of vertical center line (m) (Angle  $x=x$ ).
3. Assemble valve arm (h) as shown for specific assembly. On the right hand assembly there must be one notch between the cast mark (k) on the valve arm and the cast mark (j) on the stop plate (j above k). On the left hand assembly these cast marks must be in line.
4. Assemble one nut (p) on connecting rod (g) and assemble clevis to the other end of the connecting rod a distance of 1".
5. Insert end of connecting rod through register arm link and assemble clevis (f) to valve arm (h) using upper hole (See Figure 6). Insert clevis pin (e).
6. Open valve all the way. The opening of the valve is stopped by the set screw (b) which should project approximately 1/8" below the lug holding it. Turn shaft (o) counter clockwise to latch up mechanism. With valve held open, tighten nut (p) against register arm link. Then assemble and tighten second nut at (p).
7. Depress the emergency stop button and allow the valve to close. At this point the linkage between the valve and the register must be free. If it is not, the above adjustments must be rechecked.
8. Set the register to deliver the minimum quantity and open the valve to run product through the flowmeter.
9. After the initial trip occurs the valve should close to the intermediate flow position. This rate should be approximately 20 to 25 gpm. If the valve closes too far, unscrew clevis (f) on rod (g) to hold valve open further. If the rate of flow is too fast during the intermediate position, turn the clevis onto the rod to allow the valve to close further. It should not be necessary to turn more than one turn in either direction.
10. It is sometimes necessary to change the position of set screw (b) if the clevis has been readjusted. If the register mechanism will not latch up, unscrew the set screw to allow the valve to open further. If the connecting rod (g) is under compression, when the valve is held all the way open, turn the set screw down to relieve the pressure on the register.
11. The Preset trip adjusting screw should be near its mid-position. If a small adjustment of this screw will not permit the register to shut off "on the mark" it is usually possible to correct this by a slight adjustment of the clevis (f). This will move

## PRESET VALVE

### To Adjust Double Trip Valve Linkage With Valve At Outlet Of Flowmeter

the main valve nearer to or further away from its seat during the intermediate flow and thereby change the amount of time needed for the valve to fully close at the last trip. (Also see page 11, "To Adjust the Tripping Point").

**Note:** If it is difficult to obtain proper rate of flow during intermediate trip position and still have register latch up fully, check Preset valve to insure that it is opening all the way. Check valve by removing set screw (b) and clevis (f) from valve arm; open valve as far as possible. The distance between lug on arm and lug on stop plate must not be more than 1/4".

**VIEW LOOKING AT BACK OF REGISTER**

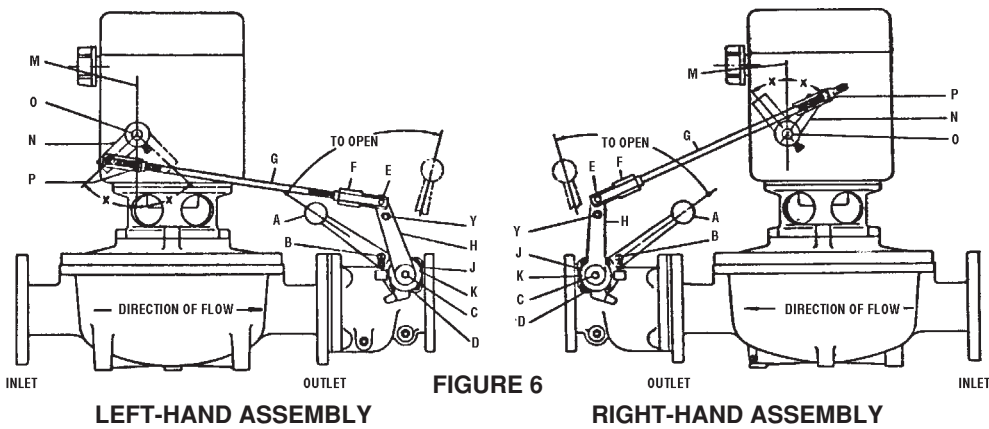

**Note:** Normal (Standard) left and right hand configurations.

**To Adjust Double Trip Valve Linkage With Valve At Inlet of Flowmeter**  
(See Note, Page 7)

1. Depress the emergency stop button on the register and turn the shaft (o) clockwise.
2. Assemble register arm (n) on knurled knob in position as shown for specific assembly. (See Figure 7). Arm should move an equal distance each side of vertical center line (m) (Angle x=x).
3. Assemble valve arm (h) as shown for specific assembly. On the left hand assembly there must be one notch between the cast mark (k) on the valve arm and the cast mark (j) on the stop plate (k above j). On the right hand assembly these cast marks must be in line.
4. Assemble one nut (p) on connecting rod (g) and assemble clevis to the other end of the connecting rod a distance of 1".
5. Insert end of connecting rod through register arm link and assemble clevis (f) to valve arm (h) using upper hole. (See Figure 7). Insert clevis pin (e).
6. Open valve all the way. The opening of the valve is stopped by the set screw (b) which should project approximately 1/8" below the lug holding it. Turn shaft (o) counter clockwise to latch up mechanism. With valve held open, tighten nut (p) against register arm link. Then assemble and tighten second nut at (p).

**To Adjust Double Trip Valve Linkage With Valve At Inlet of Flowmeter**

7. Depress the emergency stop button and allow the valve to close. At this point the linkage between the valve and the register must be free. If it is not, the above adjustments must be rechecked.
8. Set the register to deliver the minimum quantity and open the valve to run product through the flowmeter.
9. After the initial trip occurs the valve should close to the intermediate flow position. This rate should be approximately 20 to 25 gpm. If the valve closes too far, turn the clevis (f) onto rod (g) to hold valve open further. If the rate flow is too fast during the intermediate position, unscrew clevis (f) on rod (g) to allow the valve to close further. It should not be necessary to turn clevis more than one turn in either direction.
10. It is sometimes necessary to change the position of set screw (b) if the clevis has been readjusted. If the register mechanism will not latch up, unscrew the set screw to allow the valve to open further. If the connecting rod (g) is under compression, when the valve is held all the way open, turn the set screw down to relieve the pressure on the register.
11. The Preset trip adjusting screw should be near its mid-position. If a small adjustment of this screw will not permit the register to shut off "on the mark" it is usually possible to correct this by a slight adjustment of the clevis (f). This will move the main valve nearer to or further away from its seat during the intermediate flow and thereby change the amount of time needed for the valve to fully close at the last trip. (Also see page 11, "To Adjust the Tripping Point").

### To Adjust Single Trip Valve Linkage

**Note:** If it is difficult to obtain proper rate of flow during intermediate trip position and still have register latch up fully, check Preset valve to insure that it is opening all the way. Check valve by removing set screw (b) and clevis (f) from valve arm; open valve as far as possible. The distance between lug on arm and lug on stop plate must not be more than  $\frac{1}{4}$ ".

#### VIEW LOOKING AT BACK OF REGISTER

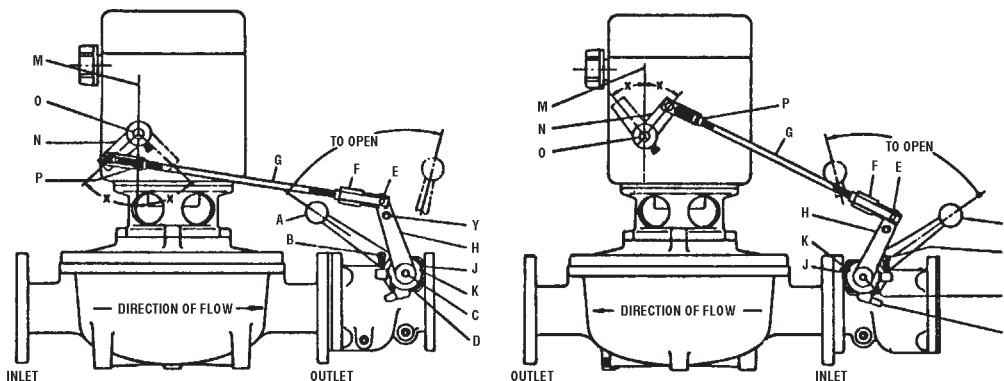

FIGURE 7

LEFT-HAND ASSEMBLY  
WITH VALVE MOUNTED AT OUTLET

RIGHT-HAND ASSEMBLY  
WITH VALVE MOUNTED AT INLET

## To Adjust Single Trip Valve Linkage

(See note, Page 7)

1. Depress the emergency stop button on the register and turn the shaft (o) clockwise.
2. Assemble register arm (n) on knurled knob in position as shown for specific assembly. (See Figure 8). Arm should move an equal distance each side of vertical center line (m) (Angle  $x=x$ ).
3. Assemble valve arm (h) as shown for specific assembly. On the right hand assembly there must be two notches between the cast mark (k) on the valve arm and the cast mark (j) on the stop plate (j above k). On the left hand assembly there must be one notch between marks (j above k).
4. Assemble one nut (p) on connecting rod (g) and assemble clevis to the other end of the connecting rod a distance of 1".
5. Insert end of connecting rod through register arm link and assemble clevis (f) to valve arm (h) using lower hole (y). Insert clevis pin (e).
6. Open valve all the way. The opening of the valve is stopped by the set screw (b) which should project approximately  $\frac{1}{8}$ " below the lug holding it. Turn shaft (o) counter clockwise to latch up mechanism. With valve held open, tighten nut (p) against register arm link. Then assemble and tighten second nut at (p).
7. Depress the emergency stop button and allow the valve to close. At this point the linkage between the valve and the register must be free. If it is not, the above adjustments must be rechecked.

## To Adjust Single Trip Valve Linkage

### VIEW LOOKING AT BACK OF REGISTER

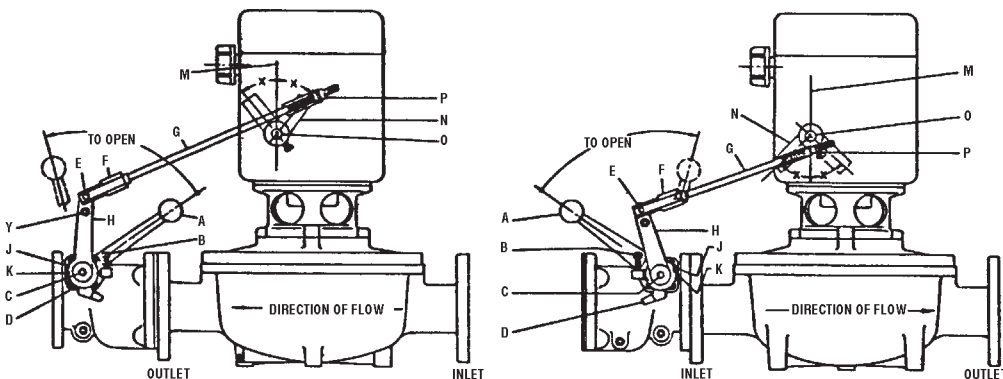

FIGURE 8

RIGHT-HAND ASSEMBLY

LEFT-HAND ASSEMBLY

**Note:** Non-standard left hand configuration.

## To Adjust The Tripping Point

The flowmeter is shipped from the factory with the Preset mechanism adjusted to trip correctly at maximum rates of flow while measuring water, or other test liquid at the factory. In the instance when the Preset does not trip at zero due to differences in liquids, rate of flow, or any other reasons, an adjustment can be made. In most cases, only a minor adjustment at the register is necessary.

The adjustment at the register is identical for both single and double trip valves. Remove the screw located in the lower right hand corner of the front register housing. Insert a screw driver into this hole and engage the slotted head of the trip adjusting screw. One turn of this screw will change the trip point about one-quarter of one graduation of the first wheel.

If the Preset trips before reaching the zero mark, turn the adjusting screw in a clockwise direction. If the Preset trips after the zero mark, turn in a counter-clockwise direction.

In some instances on Double Trip Valves an adjustment of the valve linkage may be required in order to have the Preset trip at the correct point. (See pages 8 and 9).

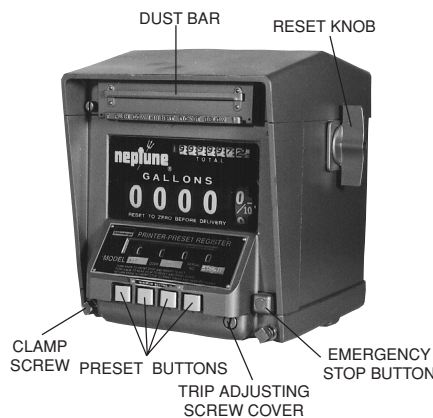

**FIGURE 9**  
**PRESET 800 SERIES**  
**PRINTER REGISTER**

## MEASURING CHAMBER

### To Remove and Disassemble

This operation is not difficult and may be performed by any competent mechanic. No special tools are required. No trouble need be expected if these few simple, but important directions are followed. Do not open the flowmeter until you have checked over all other possible causes of erratic registration.

1. Prepare a clean surface on which to place the parts as they are removed. The parts, though sturdy, are machined to close tolerance and should be handled with care. Have a replacement gasket ready before opening the flowmeter.
2. Remove the register. (See page 5).
3. Remove gear train.
4. Remove the flowmeter cover. (Will require new gasket).
5. Remove the measuring chamber from the flowmeter casing. If the chamber sticks, it may be necessary to tap maincase to free it—insert maincase bolts in holes and hit head of bolts while pulling upward on chamber. Remove thrust roller insert plate.
6. Remove three chamber assembly screws.

## To Adjust The Tripping Point

### MEASURING CHAMBER To Remove and Disassemble

7. Remove the upper half of the chamber. Be careful not to scratch or nick any part of the chamber.
8. Lift out the disc piston by its spindle.
9. The chamber is now completely disassembled. The parts may be most easily cleaned of scale, etc., by means of a good, coarse, stiff bristle (not wire) brush and gasoline or suitable cleaning agent. All foreign matter may be removed in this manner. Do not use abrasives, such as emery cloth or sand paper.

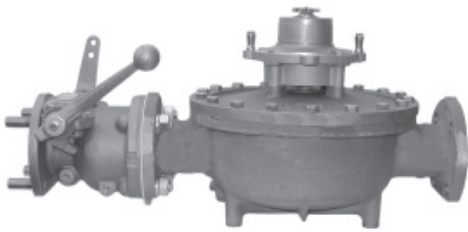

**FIGURE 10  
METER ASSEMBLED**

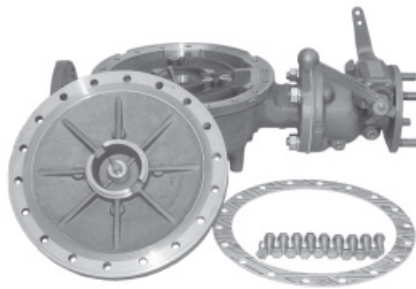

**FIGURE 11  
METER DISASSEMBLED**

#### **To Reassemble Chamber In The Flowmeter**

1. Clean the joints where the two chamber halves fit together.
2. Check that the thrust roller rotates freely in the disc piston.
3. Assemble the disc piston into the lower chamber half, aligning the slot in the former with the diaphragm in the chamber half. The disc piston cannot be dropped into the chamber vertically but must be assembled at a slight angle.
4. Assemble the upper chamber half to the lower. The diaphragm must fit into its slot in the upper half. The upper and lower halves should then snap together. Replace three screws to hold the chamber together.
5. Insert the thrust roller bearing plate. The thrust roller must not be in the path of the plate or either part may become damaged. Never use a hammer to insert the plate.
6. Operate the disc piston slowly, it should move freely without any "catch". If it does not, check that the upper and lower chamber halves are fitted tightly together. If they are, then the fault lies within the chamber and it must be disassembled to check for foreign matter or burrs.
7. Clean out the casing.
8. Lift the chamber by the piston spindle and drop it into position in the main casing. The top of the chamber should be level with the gasket seat. If it is not, pressing by hand should make it so.

#### **To Reassemble Chamber Flowmeter**

9. When replacing the cover, first inspect the gasket and then set the arm of the gear train so that it will not come down on the piston spindle.
10. Make sure that the cover is down on its seat before tightening the bolts.
11. After assembly is complete, open line valve slowly allowing liquid to gradually enter flowmeter. (Use care not to overspeed the flowmeter).

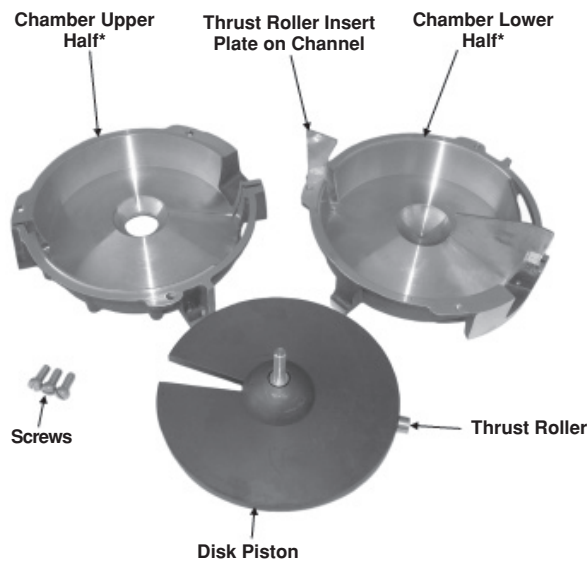

**FIGURE 12  
MEASURING CHAMBER PARTS**

\*These parts are shown for identification purposes only. Not sold as separate units.

### To Disassemble And Assemble Double Trip Valve

1. Remove valve from flowmeter.
2. Remove two screws holding retaining ring at inlet of valve.  
(Caution: End plate should be held by hand when removing screws because of spring tension beneath the plate).

All internal parts of the valve can now be removed, with the exception of the operating shaft mechanism. The removal of the internal parts from the valve body may be assisted by operating the valve handle as when opening the valve.

3. Disassemble piston and throttling ring assembly. Inspect valve seats, "O" ring gasket, piston ring, and cylinder for damaged surfaces. Replace all defective parts with new parts.
4. Reassemble piston and throttling ring assembly. Apply shellac under heads of three piston assembly screws.
5. Assemble pilot valve on pilot valve rod. Place assembly into valve body.
6. Place one end of spring over pilot valve boss.
7. Place other end of spring over boss in cylinder and press cylinder down over piston. Back of cylinder should be below flange face for proper assembly.
8. Hold cylinder in place, place "O" ring in body recess and attach retaining ring with two screws.
9. Open valve as far as possible—make sure that valve is not being stopped by set screw.

### To Disassemble And Assemble Double Trip Valve

## To Adjust Rate Of Closing Of Type 1A Double Trip Preset Valve From its Full Open Position To The Intermediate Position

Variations in the viscosity of the liquids being measured will cause changes in the rate of closing of the valve from its full open position to its intermediate position (Valve should reach its intermediate position with approximately 4 gallons remaining on Preset setting wheels).

Setting of Orifice Plate is indicated on tag attached to valve.

The rate of closing can be adjusted by changing the position of Orifice Plate which is readily accessible through inlet of valve. (Valve does not have to be disassembled).

Position of Orifice Plate can be changed by removing Screw and Lock Washer and turning plate.

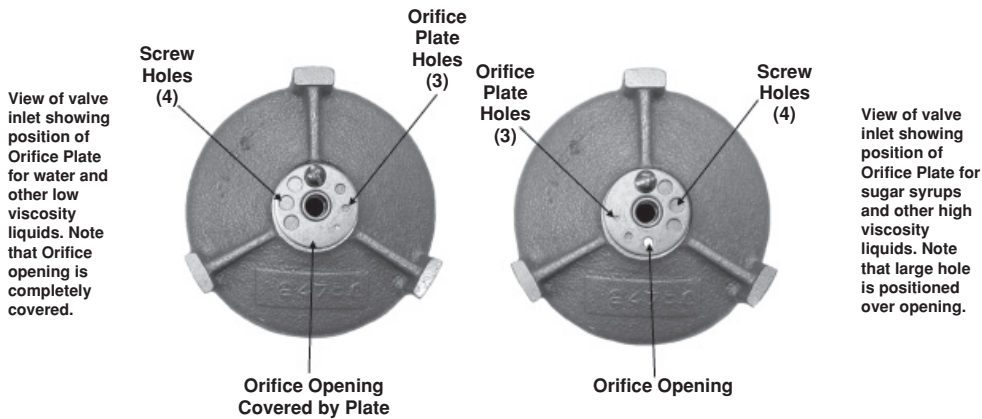

**FIGURE 13**  
**ORIFICE PLATE**

1. The normal position of Orifice Plate in valve to be used with water or other low viscosity liquids will be set with Orifice opening covered. If valve closes too slowly with this setting, turn plate counter clockwise to expose either small, medium or large hole as required.
2. The normal position of Orifice Plate in valve to be used with sugar syrups or other high viscosity liquids will be set with large hole over Orifice opening. If valve closes too quickly with this setting turn plate clockwise to expose either of the two small holes or covering the orifice, as required.

## To Disassemble And Assemble Single Trip Valve

1. Remove valve from flowmeter.
2. Remove two screws holding retaining ring at inlet valve.

(Caution: End plate should be held by hand when removing screws because of spring tension beneath the plate).

## To Adjust Rate Of Closing Of Type 1A Double Trip Preset Valve From Its Full Open Position To The Intermediate Position

## To Disassemble And Assemble Single Trip Valve



All internal parts of the valve can now be removed with the exception of the operating shaft mechanism. The removal of the internal parts from the valve body may be assisted by operating the valve handle as when opening the valve.

3. Disassemble valve disc assembly. Inspect valve disc and "O" ring gasket for damaged surfaces and replace all defective parts.
4. Reassemble disc assembly. Apply shellac under heads of three screws.
5. Install disc assembly into valve body.
6. Place one end of spring over boss on disc assembly.
7. Place other end of spring over boss in spring retaining ring and attach to valve body with two screws.

### **To Inspect Operating Shaft Seals of Auto-Stop Valves**

The following steps should be followed for both Double and Single Trip Valves if it becomes necessary to disassemble the operating shafts because of leakage or mechanical failure. A leaking shaft seal cannot be corrected by excessive tightening of the bearing bracket screws. In this case new shaft seals are usually required. (See parts list P401).

1. Remove valve handle connecting rod arm, two stop plates and two rollpins. Remove eight screws and pry off two shaft bearing brackets. Do not damage gaskets.
2. The two shaft seals can be inspected for damaged surfaces. Replace any defective seals.
3. To remove the operating shaft and two shaft bearings, first remove the two screws in the valve operating cam. Inspect the shaft for score marks and replace if necessary. New seals are worthless if used with a badly scored shaft.
4. Reassemble the operating shaft and cam.
5. Replace two shaft bearings, two seals, two bearing brackets and flat gaskets, two rollpins, two stop plates, connecting rod arm and valve handle.

## **STUFFING BOX**

### **Leakage At The Stuffing Box**

Leakage just below the register or below the gear train adapter on exterior gear train flowmeters, is the sign of a leaking stuffing box.

### **Loose Or Worn Stuffing Box Nut**

Remove the register. (See page 5). If tightening the stuffing box nut by the fingers does not stop this leak, replace with a newly packed nut or u-cup. It may also be necessary to replace the spindle. These nuts are carefully packed and the hole

### **To Inspect Operating Seals of Auto-Stop Valve**

## **STUFFING BOX**

### **Leakage At The Stuffing Box**

### **Loose Or Worn Stuffing Box Nut**

machine-reamed to the size of the spindle at the factory. Do not try to repack because hand packed nuts cause excessive friction and scoring of the spindle.

### To Replace The Gear Train

1. Remove the register and register adapter on internal gear train models. On external gear train models, the gear train is integral to the adapter; replacing the adapter replaces the gear train.
2. Remove star or fork connection on flowmeter stuffing box spindle using a No. 8 Allen Wrench.
3. For internal gear train models remove the flowmeter cover with gear train assembly attached. Keep dirt out of the flowmeter and avoid damage to the cover gasket.
4. Unscrew the stuffing box nut (1).
5. Remove the clamp nut (2); gear train assembly can be removed from the under side of flowmeter cover.

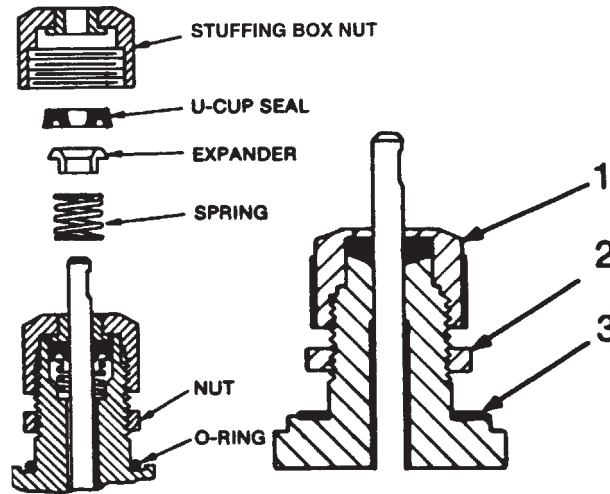

FIGURE 14  
STUFFING BOX NUT

### To Replace The Gear Train

## GENERAL MAINTENANCE

## GENERAL MAINTENANCE

In the maintenance of Actaris Neptune Type "S" Flowmeters, little is necessary other than to see that the proper conditions of operation are preserved. These conditions, once the flowmeter has been properly installed, consist merely in guarding against foreign matter, such as sediment and air, entering the measuring chamber and excessive heat from damaging the disc piston. Also do not permit flowmeter to be operated at a rate of flow greater or less than recommended.

### Sediment

The liquid passing through the measuring chamber must be free of grit and other forms of sediment in order to prevent unnecessary friction and the scoring of the piston and chamber. Evidence of trouble from this source will be found in the under-registration of the flowmeter.

Periodic cleaning of the strainer at the inlet of the flowmeter will help to insure against this trouble. In the design of this unit, particular care has been taken to make this operation as simple as possible.

### Sediment

---

**Air**

Being an instrument which measures by volume, a flowmeter will record the passage of air as well as the liquid being measured. Over-registration is the result. The air release valve is intended to prevent this condition by venting this air before it passes through the measuring chamber.

2" Type 3B units, due to the limited available space, will not separate an emulsion of air and liquid. Even tank air release valves will not efficiently separate air from extremely viscous liquids.

**Testing**

Test with a volumetric prover of sufficient capacity for one minute at maximum flow rate. Instructions for calibration are on pages 4 and 5.

Preset Flowmeters should first be tested and adjusted without the Preset (set the register for more than the test quantity), then tested with the Preset.

**Storage**

Before a flowmeter is put into storage, the measuring chamber must be flushed with

**Air****Testing****Storage**

suitable liquid which will not damage the disc piston.

## TROUBLESHOOTING GUIDE

## TROUBLESHOOTING GUIDE

- 1. Register Not Working when Liquid is Flowing**  
By-Pass around flowmeter not shut off.  
Frozen condensation inside register.  
Register in need of repair (See page 5).  
Sheared key on Change Gear — caused by ice in register. (See page 5).
- 2. Leakage at the Stuffing Box**  
Loose or worn stuffing box nut u-cup, or worn spindle.
- 3. Chronic Leakage at the Main Case Gasket**  
Broken gasket or loose bolts.  
Excessive line or shock pressure.
- 4. Reduction in the Rate or Complete Stoppage of Discharge.**  
On gravity or hydraulic systems or on pump systems (pump laboring):  
Blocked strainer due to sediment or frost.  
Shut off valve in air release chamber closed, check air release mechanism.  
(Type 3B Air Release Valve).  
On pump systems (pump not laboring):  
Pump bypass stuck open.  
Air release valve fails to close allowing liquid to escape out the vent.  
Worn pump.
- 5. Over-Registration — Erratic**  
On pump systems:  
Air release valve jamming or air vent plugged allowing air to pass through the flowmeter.  
Leaks in the suction line such as at valves, valve stems, pump packing, or flange gaskets causing an emulsion of air and liquid.  
Air pockets in closed-end piping in the suction line. Excessive suction caused by valves only partly open, suction piping too small or suction lift too great.
- 6. Under-Registration — Erratic**  
Dirt in the measuring chamber. (See pages 11 and 12.)  
Badly worn measuring chamber.  
Main casing distorted or damaged.  
Dirt under the seat of the measuring chamber at the outlet port (after cleaning).  
Leakage around the flowmeter due to partly open valve.  
Damaged internal parts.
- 7. Consistent Over- or Under-Registration**  
Flowmeter in need of calibration. (Refer to Form TSG-310).
- 8. Liquid Leaking Out the Air Release Vent**  
Worn, damaged or defective Air Release Valve unit.

---

**9. Valve Will Not Latch Open**

Adjust Valve Connecting Link. (See Pages 7 and 8).

**10. Cut Off is Not Accurate**

Adjust the Tripping Point. (See page 11).

**11. Auto-Stop Valve Closes Too Soon**

(See pages 7 and 8).

**12. Auto-Stop Valve Fails to Close**

Dirt in valve piston.

Improper linkage. (See pages 7 and 8).

# DIMENSIONS

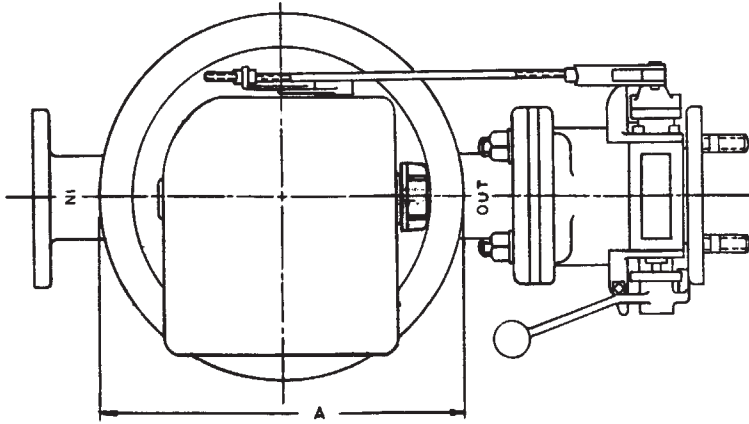

SIZE OF METER	A	B	C	D	E	F
1 1/2"	10 1/16"	6 1/2"	13"	2 3/8"	5 15/16"	18 11/32"
2"	12 1/4"	8 1/2"	17"	3 1/2"	7 5/16"	19 3/4"

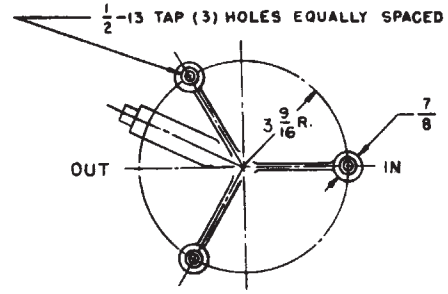

BOTTOM VIEW OF 1 1/2" MAIN CASE

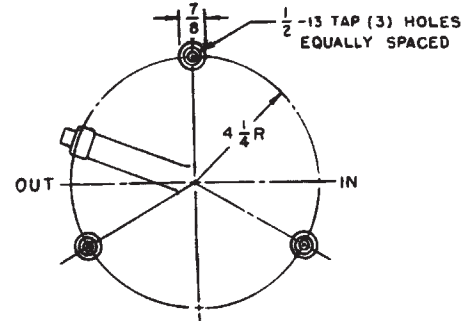

BOTTOM VIEW OF 2" MAIN CASE

