

M-101
Rev. C

Type S Flowmeters:
 $\frac{5}{8}$ " , $\frac{3}{4}$ " and 1" with
157 & 600 Series Registers



Operating and Maintenance Manual for **neptune** Type S Flowmeters



TABLE OF CONTENTS

Installation & Operation.....	Page 1
Calibration	Page 2
Register Maintenance	Page 4
Measuring Chamber Maintenance	Page 5
General Maintenance	Page 6
Troubleshooting.....	Page 7

TYPE S FLOWMETERS

INSTALLATION & OPERATION

For correct installation of Type S Flowmeters, the experience of Actaris is always available for your assistance. Do not hesitate to call the nearest Actaris authorized distributor.

MATERIALS OF CONSTRUCTION

- Main Case: Bronze (ASTM B145 Alloy 844)
- Other metal components
- Nutating Disk: Glass Phenolic Laminate (Ryton or equivalent)
- Diaphragm and Shafts: 304 SS
- Gaskets: Viton "A", Main Case Gaskets are Klingersil C4401

Before Installing the Flowmeter

Plan the installation in such a way as to allow the strainer to be coupled directly to the inlet of the flowmeter. Where this is not possible, any piping between these units should be thoroughly cleaned out.

Be careful to allow room for easy removal of the strainer basket.

Where an air release valve is used, it should be installed in a position as close as possible to the inlet of the flowmeter. This will insure the removal of the greatest possible amount of air from the liquid before metering.

Piping

- Coupling sets are provided with all 5/8 - 1" Type S Meters for ease in installation and removal during start-up system flushing.

Use seal tape or pipe cement on male threads only.

On open-ended systems the piping on the outlet side of the flowmeter should be so arranged as to eliminate the possibility of draining the measuring chamber. Where a trap is not possible, an anti-drain valve is recommended.

Experience has shown the need for a valved bypass connection to be installed around the flowmeter. This arrangement permits product flow in the event that the flowmeter must be removed for repair.

All piping connected to the flowmeter must be firmly secured and supported to prevent strain on the flowmeter casing.

Orientation of Meter

- Normally horizontal, left to right hand flow.

Air Vent Line

Where an air release valve is used, the vent pipe should be 3/4" inside diameter pipe or tubing. Care should be taken to prevent any possible obstruction to the free flow of air in this line. This line should be connected to a drip collecting drum, or to the supply tank at lower than line pressure.

When Installing

The connecting piping should be firmly secured to prevent strain on the flowmeter casing. Care should be taken that there is provision for expansion due to change in temperature.

All piping on the inlet side of the flowmeter should be thoroughly cleaned. Whenever possible, place a spool in the place of the flowmeter and flush all lines thoroughly before the flowmeter is installed. The majority of service calls on new installations will be eliminated if these directions are followed.

Inlet and outlet are clearly marked; do not install backwards.

INSTALLATION & OPERATION

MATERIALS OF CONSTRUCTION

Before Installing The Flowmeter

Piping

Orientation of Meter

Air Vent Line

When Installing

600 Series Register

If it is necessary to change the direction in which the register will face with respect to the pipe, follow these directions:

1. Loosen the clamps holding the register to the flowmeter.
2. Turn the register to the desired position and tighten the clamps.

Model 157 Register

1. Remove register box screws.
2. Remove register box.
3. Turn the register to the desired position and reinstall the register box and screws.
4. Tighten register box screws.

Open line valves slowly allowing liquid to gradually enter flowmeter. Use care not to overspeed the flowmeter. This may cause damage and/or premature wear of internal components.

After Installing

Pass sufficient liquid through to clear the line of air.

Check the rate of flow. It should not exceed the rated capacity of the flowmeter.

The bypass on the pump should be so regulated as to deliver the maximum practical rate of flow for the least amount of pressure. Pressure on the flowmeter should not exceed 150 psi. Do not try to increase the rate of flow through undersized pipes and fittings by means of excessive pressures which will cause leaking gaskets and collapsed air release floats.

Temperature of the liquid should not exceed that specified for the flowmeter.

While all flowmeters are carefully calibrated at the factory it is recommended that flowmeters be tested and if registration appears inaccurate, see "Calibration" to locate trouble.

Cleaning The Strainer

While the installation is still new, the strainer should be cleaned very frequently. After the system has had a chance to be thoroughly washed out, periodic cleaning is recommended.

To Operate The Flowmeter

To reset the 600 Series Register to zero, push in the reset handle at the right side of the register and rotate clockwise.

CALIBRATION

Tests of flowmeters should be of sufficient quantity (volume) so that the readability of the register allows an accurate test. Minimum test quantity is the amount metered in one minute at normal flow.

Erratic Registration

Erratic registration is an indication of trouble in the system, usually caused by air or dirt in the measuring chamber. Do not try to correct this by recalibration of the flowmeter, but first check over the piping for air leaks, clean the strainer and then, if the trouble has not been found, clean the flowmeter as directed in the section, "Flowmeter Measuring Chamber". If this does not correct the trouble, check for faulty installation.

Over-registration is an indication of air, whereas under-registration is generally caused by dirt or pipe scale in the measuring chamber, or the liquid bypassing the flowmeter in some manner.

Consistent Over- or Under Registration

When the flowmeter registers consistently either more or less than is delivered, the calibration may be corrected in the following manner:

To Turn 600 Series Register

To Turn Register Model 157 Register

After Installing

Cleaning The Strainer

To Operate The Flowmeter

CALIBRATION

Erratic Registration

Consistent Over- or Under-Registration

SAMPLE CHANGE GEAR CHART

	REG GEAR	STUFF BOX GEAR	CHANGE	
			%	CU IN in 50 US GAL
↑	26	28	27	31
↑	27	29	24	28
↑	28	30	23	27
↑	29	31	21	24
↑	30	32	20	23
↑	31	33	18	21
↑	32	34	18	21
↑	33	35	17	20
↑	34	36	32	37
↑	18	19	27	31
↑	19	20	24	28
↑	20	21	23	27
↑	21	22	21	24
↑	22	23	19	22
↑	23	24	18	21
↑	24	25	16	19
↑	25	26	15	17
↑	26	27	15	17
↑	27	28	12	14
↑	28	29	11	13
↑	29	30	12	14
↑	30	31	20	23
↑	32	33	26	30
↑	35	36		
↓				

This chart is reproduced for illustration purposes only. If the gears on your flowmeter do not correspond with those on the chart, contact your nearest Actaris authorized distributor, giving flowmeter size, register type, dial capacity and unit measure.

Figure 1. Register Change Gears

Model 157 Register:

1. Remove the register from the flowmeter by removing screws holding the register to the flowmeter.
2. On the stuffing box spindle of the flowmeter will be found a gear known as the "Stuffing Box Change Gear." This gear meshes with and drives a similar gear known as the "Register Change Gear" on the register. Note the numbers stamped on these gears. Now refer to the Change Gear Chart and locate this pair of gears.
3. If the flowmeter is under-registering (delivering too much), select a new pair of gears farther up on the chart. If the flowmeter is over-registering (delivering too little), select a new pair of gears farther down on the chart. The right hand columns show the difference in delivery between each successive pair to use; see example.
4. Remove the old Change Gears and replace

with the new pair. (New gears may be obtained from the nearest authorized distributor.) To remove the Register Change Gear, close the split end of the spindle with a pair of pliers and pull off the gear. After slipping on the new gear, spread the ends of the spindle slightly. The Stuffing Box Change Gear should pull off easily and the new one should slide on without forcing. **Do not spread the ends of the stuffing box spindle.**

5. Reassemble the flowmeter, run a few gallons through and retest.

600 Series Register

The 600 Series Register Change Gears are located inside the register, directly beneath an access plate on top of the register. Remove the two screws on the plate, the cover plate, and the gasket. Replace the gears as above. NOTE: The stuffing box and register change gears are identified by "S" and "R" stamped on the gear plate. Spread the ends of both spindles and reassemble the cover plate. Run a few gallons through and retest.

Example: Suppose, for instance, that a flowmeter has an 18-tooth register change gear, and a 19-tooth stuffing box gear and that when 50 gallons have been registered on the dial, the flowmeter has actually passed 80 cubic inches more than 50 gallons. This is .69% under-registration.

Changing the gears to the 34-36 combination would cut down the delivery by .32% cubic inches so that the over-delivery would then be only .37%. Going to the next combination, 33-35, would cut down the delivery .17% more, and the next, 32-34, still .18% more, making a total of .32% + .17% + .18% or .67%.

In this instance, therefore, a 32-tooth gear should be used on the register and a 34-tooth gear on

Model 157 Register

600 Series Register

MAINTENANCE

Register

Register parts are such that only minor field repairs are advisable. When a register is in need of extensive service or repair other than that for which instruction is given here, it is recommended that the register be returned to the nearest Actaris authorized distributor for repair. If a replacement register is needed, be sure and specify the exact model of the register replaced as well as the change gears in the register.

Model 157 Register — To Clean The Register

To remove register from flowmeter, remove the screws holding register to the flowmeter.

1. Remove the mechanism from its housing.
2. Blow out the dirt with compressed air. Do not use brushes.
3. Wash the dial face with soap and water. Do not use gasoline or kerosene. In case the dial only is to be washed, it is not necessary to remove the mechanism from its housing.
4. Replace the mechanism in its housing.

600 Series Registers — Repair of Register

Register parts are such that only minor field repairs are advisable. When a register is in need of repair or service other than that for which instruction is given here, it should be returned to the Actaris authorized distributor. Maintenance of the register is limited to cleaning and to those operations which will locate the sources of possible trouble without removing the register from the flowmeter.

When ordering a replacement register, specify the register model, code and serial number (stamped on register nameplate).

When replacing the register, remove the change gears from the old register and transfer them to the new register. (This will maintain original flowmeter calibration.)

Cleaning

Regularly clean the housing to remove accumulations of dirt and grease, or chemical deposits.

CAUTION: Use only mild detergents and water to clean the register window. Do not use abrasives or spray type cleaners, or solvents and thinners which may soften or cloud the plastic window.

To Remove Housing From Mechanism

1. Remove two screws and access plate on top of register.
2. Push in reset knob and partially reset to retain shaft in reset position.
3. Remove reset knob screw and four screws on bottom plate.
4. Pull out on reset knob to disengage knob from shaft.
5. Loosen and slide housing to knob end and remove. Caution is advised in removal of housing to avoid scraping visible wheels.
6. Reset shaft can be turned to normal position.

To Remove Register From Flowmeter

Remove the two clamps holding the register adapter to the flowmeter, and lift off the register.

MAINTENANCE Register

Model 157 Register To Clean The Register

600 Series Registers Repair of Register

Cleaning

To Remove Housing From Mechanism

To Remove Register From Flowmeter

To Reinstall Register To Flowmeter

Carefully align input shaft of register with the star connection on gear train of flowmeter and install the two register clamps.

MEASURING CHAMBER MAINTENANCE

To Remove and Disassemble

This operation is not difficult and may be performed by any competent mechanic. No special tools are required. No trouble need be expected if these few simple, but important directions are followed. Do not open the flowmeter until you have checked over all other possible causes of erratic registration.

1. Prepare a clean surface on which to place the parts as they are removed. The parts, though sturdy, are machined to close tolerance and should be handled with care. Have a replacement gasket ready before opening the flowmeter.

2. Remove the flowmeter cover.

3. Remove the measuring chamber from the flowmeter casing. If the chamber sticks, it may be necessary to tap maincase to free it — insert maincase bolts in holes and hit head of bolt. Remove thrust roller insert plate or channel. Remove the three screws holding the chamber together and the thrust roller insert plate or channel.

4. Pry open the chamber with a piece of hard wood inserted into the inlet port. Be careful not to damage the disc or to scratch or nick any part of the chamber. Remove the upper half of the chamber. Be careful not to scratch or nick any part of the chamber.

5. Lift out the disc piston by its spindle.

6. The chamber is now completely disassembled. The parts may be most easily cleaned of scale, etc., by means of a good, coarse, stiff bristle (not wire) brush and gasoline or suitable cleaning agent. All foreign matter may be removed in this manner. **Do not use abrasives, such as emery cloth or sand paper.**

To Reassemble Chamber In The Flowmeter

1. Be sure that the joints are clean where the two halves fit together.

2. See that the thrust roller is perfectly free in the disc.

3. Hold the lower half of the measuring chamber in the left hand with the diaphragm towards the left. Hold the disc near the thrust roller hole, spindle up. The disc will then drop into position easily if held at a slight angle.

4. Place the thrust roller in position.

5. Place the upper half on top, making sure that the diaphragm fits in its slot. Insert the thrust roller bearing plate or channel. **Do not use a hammer.**

6. Operate the piston slowly; it should move freely without any "catch."

7. Clean out the casing.

8. Lift the chamber by the piston spindle and lower it into position in the main casing. The top of the chamber should be level with the gasket seat. If it is not, pressing by hand should make it so.

9. When replacing the cover, first inspect the gasket and then set the arm of the gear train so that it will not come down on the piston spindle.

10. Make sure that the cover is down on its seat before tightening the bolts.

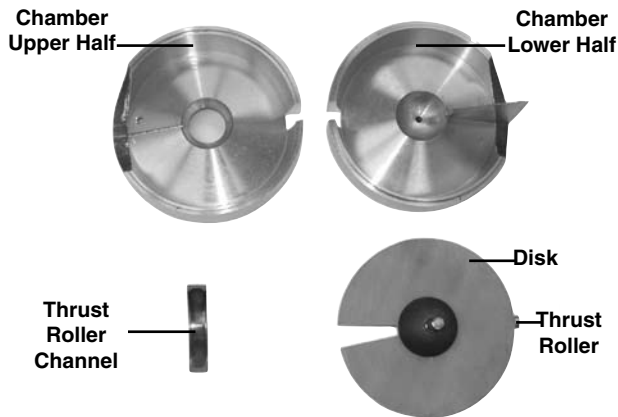

Figure 2.
Measuring Chamber Components

To Reinstall Register To Flowmeter

MEASURING CHAMBER MAINTENANCE To Remove and Disassemble

To Reassemble Chamber In The Flowmeter

To Repair Leaking “U” Cup Seal Stuffing Box

1. Remove the register (see page 4).
2. Remove the star connection (1), using a No. 8 Allen wrench.
3. Remove the stuffing box nut (2).
4. Remove shaft seal (3). Inspect upper end of spindle to be sure it is free of nicks or burrs which might damage the new shaft seal when it is placed on spindle.
5. Replace shaft seal with new part. Be sure expander (4) is in position before inserting new seal.
6. Assemble nut and tighten down all the way.

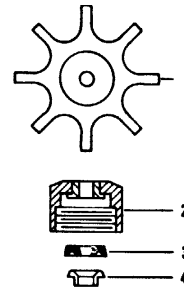

To Replace The Gear Train

1. Remove the register (see page 4).
2. Remove the star connection (1), using a No. 8 Allen wrench.
3. Remove the flowmeter cover, with gear train assembly attached. Keep dirt out of the flowmeter and avoid injury to the cover gasket.
4. Unscrew the stuffing box nut (2).
5. Remove clamp nut (6) ; gear train assembly can be removed from underside of flowmeter cover.
6. Install replacement gear train making sure that the replacement has the same reduction. *Note: **Pack gear train and housing full with non-water soluble grease on enclosed type.**
7. When replacing the cover, first inspect the gasket and then set the arm of the gear train so that it will not come down on the piston spindle.

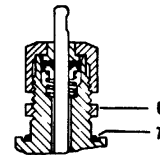

Figure 3.
Stuffing Box

GENERAL MAINTENANCE

In the maintenance of the accuracy of Actaris Type S Flowmeters, little is necessary other than to see that the proper conditions of operation are preserved. These conditions, once the flowmeter has been properly installed, consist merely in guarding against foreign matter, such as sediment and air, entering the measuring chamber and excessive heat from damaging the disc piston. Also, do not permit flowmeter to be operated at rate of flow greater or less than recommended.

Sediment

The liquid passing through the measuring chamber must be free of grit and other forms of sediment in order to prevent unnecessary friction and the scoring of the disc and chamber. Evidence of trouble from this source will be found in the under-registration of the flowmeter. Periodic cleaning of the strainer at the inlet of the flowmeter will help to insure against trouble. In the design of this unit, particular care has been taken to make this operation as simple as possible.

Air

Being an instrument which measures by volume, a flowmeter will record the passage of air as well as the liquid being measured. Over-registration is the result. The air release unit is intended to prevent this condition by venting this air before it passes through the measuring chamber.

Most compact air release units, due to the limited available space, will not separate an emulsion or air and liquid. Even tank air release units will not efficiently separate air from viscous liquids.

Testing

Instruction for calibration will be found under “Calibration” on page 2.

Storage

Before a flowmeter is put into storage, the measuring chamber must be flushed with suitable liquid which will not damage the disc.

To Repair Leaking “U” Cup Seal Stuffing Box

To Replace The Gear Train

GENERAL MAINTENANCE

Sediment

Air

Testing

Storage

TROUBLESHOOTING

1. Register Not Working When Liquid is Flowing

Bypass around flowmeter not shut off.
Stuck register due to set-back mechanism failing to release. See page 2.
Sheared key on "change gear" due to stuck register or to reverse flow through the flowmeter.
Register in need of repair. See page 4.
Disc in measuring chamber broken.

2. Leakage At The Stuffing Box

Loose or worn stuffing box nut or worn spindle. See page 6.
Bad U-Cup seal.

3. Chronic Leakage At The Main Case Gasket

Broken gasket or loose bolts.
Excessive line or shock pressure.

4. Reduction In The Rate or Complete Stoppage of Discharge

On gravity or hydraulic systems or on pump systems (pump laboring):
Blocked strainer due to sediment or frost.
Disc in flowmeter stuck due to dirt (check strainer and clean measuring chamber). See pages 1 and 5.
On pump systems (pump not laboring):
Pump bypass stuck open.
Worn Pump.

5. Over-Registration — Erratic

On pump systems:
Air release or air vent plugged allowing air to pass through the flowmeter.
Leaks in the suction line such as at valves, valve stems, pump packing, or flange gaskets causing an emulsion of air and liquid.
Air pockets in closed-end piping in the suction line.
Excessive suction caused by valves only partially open, suction piping too small or suction lift too great.

6. Under-Registration — Erratic

Dirt in the measuring chamber.
Badly worn measuring chamber.
Main casing distorted or damaged.
Leakage around the flowmeter due to partly open valve.
Damaged internal parts.

7. Consistent Over- or Under-Registration

Flowmeter in need of calibration. See page 2.

8. Liquid Leaking Out The Air Release Vent

Worn, damaged or defective valve unit.

TROUBLESHOOTING

**5/8" & 3/4" TYPE S FLOWMETERS
with 157 REGISTER**

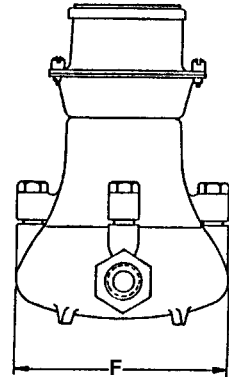
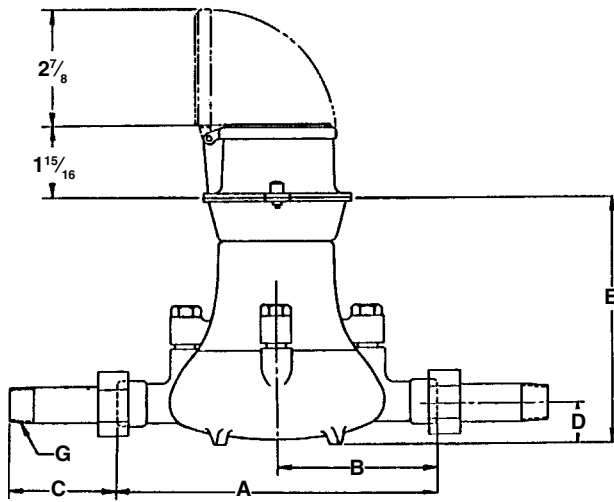

METER SIZE	A	B	C	D	E	F	G NPT
5/8	7 1/2	3 3/4	2 7/16	1	6	5	1/2-14
3/4	9	4 1/2	2 9/16	1 3/16	6 3/8	5 5/8	3/4-14

**5/8" & 3/4" TYPE S FLOWMETERS
with 600 SERIES REGISTER
with 45 PULSER**

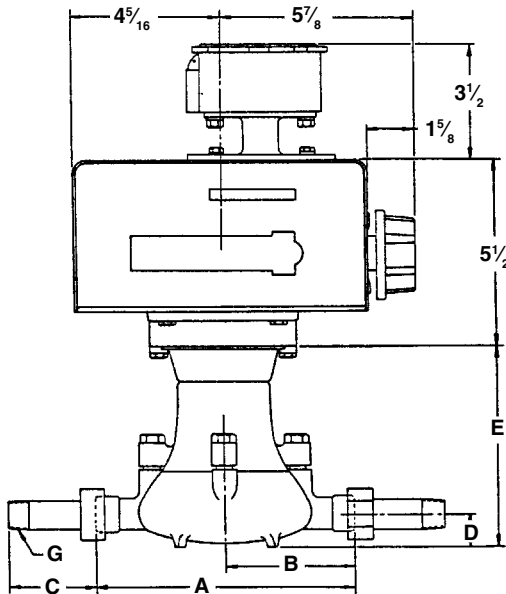

ALLOW 2 INCH
CLEARANCE FOR
REMOVING REGISTER

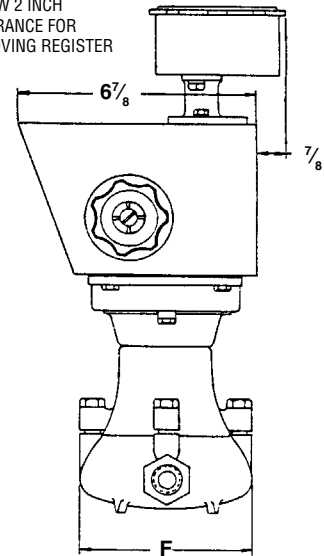

METER SIZE	A	B	C	D	E	F	G NPT
5/8	7 1/2	3 3/4	2 7/16	1	6	5	1/2-14
3/4	9	4 1/2	2 9/16	1 3/16	6 3/8	5 5/8	3/4-14

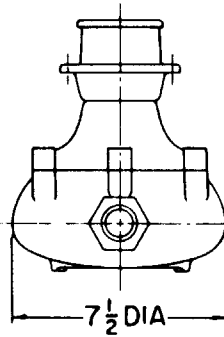
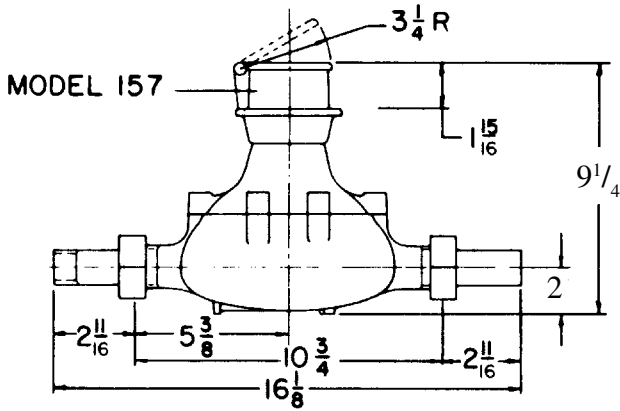
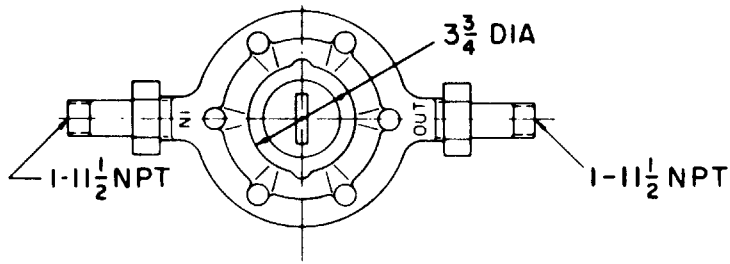

**1" TYPE S METER
with 100-SERIES REGISTER**

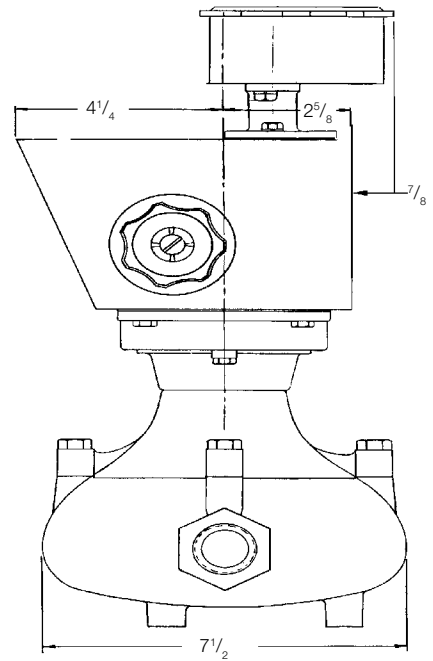
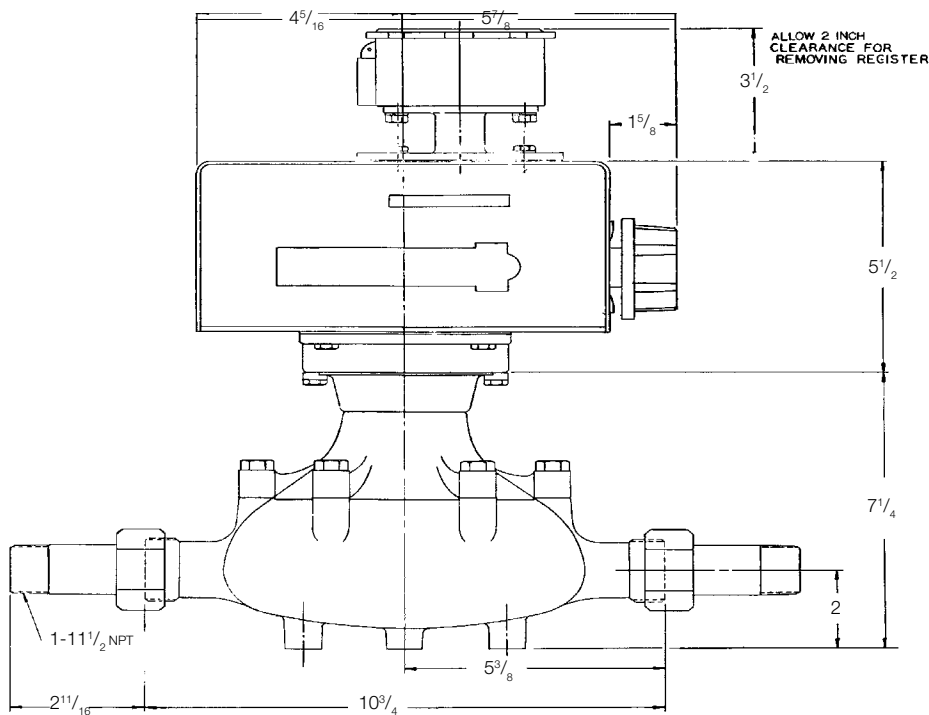

**1" TYPE S
600-SERIES REGISTER
with 45 PULSER**