



# Flow meters, Flow switches and Flow transmitters

## A Small Vane Style For Liquids

 CSA Certified NRTL/C  
 CE Marked (as noted)

**NIST** Traceable Calibration  
Certificate Available



SN Series shown with  
"A" style control box

### DESCRIPTION

These are variable area meters with a spring biased semi-circular vane that opens wider with more flow. They are installed in-line in any position. Straight pipe runs before or after the meter are not required. The simple mechanical connection directly drives pointers, switches and transmitters.

### READOUTS

The flowmeter has outputs both visual and electronic. Visual displays are either pointer (with inscribed scale) or numeric (digital LCD). Electronic outputs can be mechanical switch closure, 4-20 mA analog or both (for signal redundancy). The switches can be general purpose or rated for hazardous locations (all classes, groups and divisions). The 4-20 mA transmitters are Intrinsically Safe if used with approved barriers.

### CALIBRATION

All flow meters are individually calibrated for fluids with the viscosity you specify (up to 3000 SSU/650 Centistokes). We also compensate for your fluid's specific gravity. For NIST Traceability please consult factory.

### CONSTRUCTION MATERIALS

The meter body, internal moving parts, and seals are offered in a variety of materials to suit a wide range of applications: water, synthetic and petroleum based oils, paint, corrosives and solvents. See selections in the "How to Order" section.

### LINE CONNECTION

Ports can be threaded or flanged. See selections in the "How to Order" section.

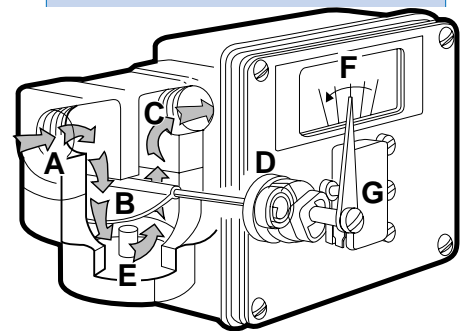

Fluid enters at A, passes around the semi-circular vane B, exits at outlet C. The vane resists the flow because of the spring D. The further the vane is pushed the larger the passageway E becomes. This minimizes the pressure drop. The vane shaft turns to operate the pointer F and remote signal devices such as the switch G.

**HOW TO ORDER** Select appropriate symbols and build a model code number, as in example shown:

**EXAMPLE:** SN - B S B 7GM V - 4 - 320V.9 -

**SERIES BY PRESSURE RATING**

Normal pressure (300 PSI)	=	SN
Medium pressure (500 PSI)	=	SM
High pressure (2000 PSI) *Note: Max pressure for 316 SS body reduced to 1500psi. Exterior bolts are not 316 SS.	=	SH

HOUSING MATERIAL	WHERE USED		
Aluminum with nylon flow chamber	Lube oil	=	A SN only
Brass with nylon flow chamber	Water	=	B
Naval bronze with nylon flow chamber	Specialty	=	W
Aluminum	Lube oil	=	D SN or SM
Aluminum (hard coated)	Lube oil with exterior corrosion protection	=	E
Brass	Water	=	F
Naval bronze	Sea water	=	U
Stainless steel (316)	Chemicals, corrosives	=	I SH, SM or SN
Cast iron	Oil	=	C
Cast iron, nickel plated	Water, oil with exterior corrosion protection	=	N
Carbon steel	Oil	=	M
Carbon steel, nickel plated	Water, oil with exterior corrosion protection	=	J

*Note: SH-I units only good to 1500 PSI. External screws not 316 SS.*

**INTERNAL MOVING PARTS**

Stainless steel (300 series)	Standard for oil	=	S
Stainless steel (316 series)	Water, chemicals and corrosives	=	I
Titanium	Sea water	=	T
Monel	Corrosives	=	L

**SEAL MATERIAL**

Buna N	Water, oil	=	B
EPR	Hot water, caustics	=	E
Viton	Acids, some caustics	=	F
Kalrez	Corrosives, solvents	=	J
Kalrez (dynamic) & Buna N (static)	Specialty	=	A
Kalrez (dynamic) and EPR (static)	Specialty	=	H
Kalrez (dynamic) and Viton (static)	Specialty	=	K
Kalrez (dynamic) and Teflon (static)	Corrosives, solvents	=	T
	No good on A,B or W bodies	=	T

**MAX FLOW RATE LIQUIDS**

Viscosity minimum (SSU/Centistokes)					
	500/110	250/55	100/20	None	
GPH:	30	60	90, 120	180, 240, 300, 200, 300, 400, 500, 600, 700, 800, 900, 1000, 1200	= GH
GPM:	.5	1	1.5, 2	3, 4, 5, 6, 7, 8, 9, 10, 15 & 20	= GM
LPM:	2	4	6, 8	10, 15, 20, 25, 30, 35, 40, 45, 50, 60, 75	= LM
LPH:	100	200	350, 500	600, 700, 800, 900, 1000, 1500, 2000, 2500, 3000, 3500, 4000	= LH
CMH:	.1	.25	.35, .5	.75, 1, 1.25, 1.5, 2, 2.5, 3, 3.5, 4, 4.5	= CMH

**Hand operated globe valve integral to flowmeter body (SN series only)**

No Valve	=	No Symbol
Valve (brass)	=	V
Not available on carbon steel or stainless steel housings.		

**THREADED ATTACHMENT**

Pipe size and attachment method	Pipe Size In Inches	NPT	SAE	BSPB	BSPT	Max Flow In GPM
	1/4	2	4T	4BP	4BT	8
	3/8	3	6T	6BP	6BT	8
	1/2	4	8T	8BP	8BT	12
	5/8		10T	10BP	10BT	15
	3/4	6	12T	12BP	12BT	20

**FLANGED**

Ex: 2FWCS150RF = 1/4", Welded, Class 150, Raised Face flange

Pipe Size In Inches	Attachment	Material	Class	Style
2 = 1/4"	FW=Welded	CS=Carbon Steel	150	RF=Ansi raised face
3 = 3/8"	FT=Threaded	S=316 Stainless	300	
4 = 1/2"			600	
6 = 3/4"				
8 = 1"				

**FLUID CHARACTERISTICS**

Viscosity number followed by a 'V' (for SSU), 'C' (for centipoise), or 'CS' (for centistokes) followed by the specific gravity. Example: **320V.9** would indicate a fluid with a viscosity of 320 SSU with a specific gravity of .9. For dual viscosities (where there is a start up viscosity or where there may be a range) put in both values with a slash. Example: 320/150V.9.

**A1 W L - ST - 2D**

SERVICE		
Oil and dust tight (Type 12)	=	<b>N</b>
Weatherproof (Type 4)	=	<b>W</b>
Weatherproof, corrosion proof (Type 4X)	=	<b>X</b>

FLOW DIRECTION		
Left to right	=	<b>R</b>
Right to left	=	<b>L</b>
Up	=	<b>U</b>
Down	=	<b>D</b>

SPECIAL OPTIONS		
High-temp- 400°F for A & R Box, 300°F for transmitter options	=	<b>HT</b>
Stainless steel ID tag for customer supplied information	=	<b>ST</b>
Pin connector (See explanation for special options.)	=	<b>PC</b>
CSA enclosure / PVC window	=	<b>C</b>
Tempered glass window	=	<b>TG</b>
Clearance vane for ≥ 5 GPM	=	<b>Z86</b>
Foot mount bracket	=	<b>F</b>
Wall mount bracket	=	<b>W</b>

SWITCH SETTING		
No symbol	=	Lowest possible setting (usually 10% of maximum flow)
Desired set point is assumed to be in flow units already selected (GPM). Give flow rate followed by a "D" for flow going down (flow failure) or a "U" for flow going up.		<b>2D</b>
Example, 2D indicates a setting of 2 GPM in declining flow.		

**CONTROL BOX & READOUT**

Basic Features ↓	Additional Options ↓	Standard resolution pointer and inscribed scale			High resolution pointer and inscribed scale	Separate junction boxes (with terminal strips) for switch & transmitter
		"A", "L" and "Z" Box			"R" Box	"T" Box
		Materials of Construction				
		Polysulfone	Aluminum	316 Stainless	Aluminum	Aluminum
These options all include inscribed scale and pointer plus one of the standard (non hazardous location) switches selected to the right.	No switch	<b>A0</b>	<b>L0</b>	<b>Z0</b>	<b>R0</b>	
	One SPDT (3 wire), CE	<b>A1</b>	<b>L1</b>	<b>Z1</b>	<b>R1</b>	
	One high vibration SPDT (3 wire), CE	<b>A1B</b>	<b>L1B</b>	<b>Z1B</b>		
	Two SPDT (3 wire), CE	<b>A2</b>	<b>L2</b>	<b>Z2</b>	<b>R2</b>	
	Two high vibration SPDT (3 wire), CE	<b>A2B</b>	<b>L2B</b>	<b>Z2B</b>		
	One SPDT (4 wire)	<b>A3</b>	<b>L3</b>	<b>Z3</b>	<b>R3</b>	
	Two SPDT (4 wire)	<b>A4</b>	<b>L4</b>	<b>Z4</b>	<b>R4</b>	
	One SPDT (3 wire) high temperature	<b>A61</b>	<b>L61</b>	<b>Z61</b>	<b>R61</b>	
	Two SPDT (3 wire) high temperature	<b>A62</b>	<b>L62</b>	<b>Z62</b>	<b>R62</b>	
	One SPDT (3 wire) gold contact	<b>A71</b>	<b>L71</b>	<b>Z71</b>	<b>R71</b>	
Two SPDT (3 wire) gold contact	<b>A72</b>	<b>L72</b>	<b>Z72</b>	<b>R72</b>		
These options all contain inscribed scale with pointer plus hazardous location switches selected to the right. Note that the box is not rated, only the switches.	One SPDT hazardous location (all classes, groups and divisions)				<b>R7</b>	
	One DPDT hazardous location (all classes, groups and divisions)				<b>R17</b>	
	Two SPDT hazardous location (all classes, groups and divisions)				<b>R18</b>	
	Two DPDT hazardous location (all classes, groups and divisions)				<b>R19</b>	
	One SPST hazardous location proximity (all classes, groups and divisions)				<b>R30</b>	
	Two SPST hazardous location proximity (all classes, groups and divisions)				<b>R31</b>	
	One SPDT (3 wire) hermetically sealed	<b>A53</b>	<b>L53</b>	<b>Z53</b>		
	Two SPDT (3 wire) hermetically sealed	<b>A54</b>	<b>L54</b>	<b>Z54</b>		
These options all contain a 4-20 mA transmitter and one of the selections to the right.	No switches (Intrinsicly safe with barrier)	<b>AX0</b>	<b>LX0</b>	<b>ZX0</b>	<b>RX0</b>	<b>TT0</b>
	One SPDT (3 wire), CE				<b>RX1</b>	<b>TT1</b>
	One SPDT (4 wire)				<b>RX3</b>	<b>TT3</b>
	One SPDT (3 wire) high temperature				<b>RX61</b>	<b>TT61</b>
	One SPDT (3 wire) gold contact					<b>TT71</b>
	One SPDT (3 wire) hermetically sealed					<b>TT53</b>
These options all include a 4-20 mA transmitter with a digital LCD display plus one of the selections to the right.	No switches					<b>TTL0</b>
	One SPDT (3 wire), CE					<b>TTL1</b>
	One SPDT (4 wire)					<b>TTL3</b>
	One SPDT (3 wire) high temperature					<b>TTL61</b>

## ENGINEERING DATA

**Maximum fluid temperature:** 200°F (95°C)

**Optional max. fluid temperatures:**  
300 & 400°F (150 & 205°C) (option HT)

**Maximum ambient temp:** 150°F (65°C)  
CSA listed only to 105°F (40°C)

**Series SN max. operating pressure:**  
(3:1 safety factor): 300 PSI (20.69 BAR)

**Series SM max. operating pressure:**  
(2:1 safety factor): 500 PSI (34.48 BAR)

**Series SH max. operating pressure:**  
(3:1 safety factor) 2000 PSI (137.93 BAR)  
Stainless Steel with special option Z67SH,  
1500 PSI (103.42 BAR)

**Readout accuracy, full scale:** ±5%

**Repeatability of switches 1% of actual flow rate**

## FLOW & PRESSURE DROP

Maximum flow ranges to 8 GPM/32 LPM = pressure drop from 1.9 to 2.5 PSID (2.2 PSID average).

Maximum flow ranges to 9 to 12 GPM/45 LPM = pressure drop from 1.9 to 4 PSID (2.95 PSID average).

Maximum flow ranges to 15 GPM/56 LPM = pressure drop from 1.9 to 5 PSID (3.5 PSID average).

Maximum flow ranges to 16 GPM/60 LPM = pressure drop from 1.9 to 5.5 PSID (3.7 PSID average).

Maximum flow ranges to 20 GPM/75 LPM = pressure drop from 1.9 to 6 PSID (4.0 PSID average).

## INSTALLATION

Flow monitors mount in-line and are typically supported by rigid pipe.

## SPECIAL OPTIONS

**High temperature:** (option HT) requires all-metal construction of housing/orifice cover with seals of Viton, EPR, Kalrez or Teflon (compatible with fluid). A thermal barrier (heat-resistant cloth) is added between the housing and the control box, which must be used with service option "W" (weatherproof) or "X" (corrosion resistant). A metal scale is provided.

**Identification tag:** (option ST) customer-supplied information is stamped on a stainless steel tag that is attached to the nameplate.

**Multi-pin connector:** Pin connectors (option PC) are available for rapid field installation. Meters are provided with the male half of either a micro or a mini pin connector. Check the chart below for the number of pins required for your control box selection and current type. Insert the number of pins in the code PC\_\_ for a mini connector or PC\_\_M for a micro connector. For example, a PC5 would be a 5 pin mini and PC5M would be a 5 pin Micro. (See table below for number of pins required for each option.)

**Tempered-glass window:** (option TG) replaces the standard window. A tempered-glass window is employed where airborne solvents or high-ambient temperatures are common.

**Clearance vane:** (option Z86) the swing vane is modified to provide extra clearance for liquids that contain particulate. Available for maximum flow range of 5 TO 9 GPM. This reduces the turndown. The minimum flow is 1.5 GPM. Z86 is standard for maximum flows 10 to 20 GPM.

Number of pins required for various combinations of current type, box type and switch option.

	AC switch options			1, 1B, 61, 71			3		
	DC switch options	0	1, 1B, 61, 71	3	2, 2B, 54, 62, 72		53		
Box	A		3	4	6	5	3	4	
	R		3	4	6	5	3	4	
	RT	3							
	TT	3	3	4			3	4	
	TTL	3	3	4			3	4	

\*This box allows micro pin connectors only. Eg. PC3M or PC5M.

## CONTROL BOX SELECTION GUIDE

### “A” Box



“A” box is selected for price and simplicity.

It holds switches (general purpose and hermetically sealed) or 4-20mA transmitter.

You get this control box when you order any CONTROL BOX & READOUT starting with an “A” (see "How to Order" page). Examples: A1WR is a one switch, weatherproof box with flow from left to right.

This control box is made of Polysulfone (standard low cost “A”) with options for aluminum (“L”) or 316 stainless steel (“Z”).

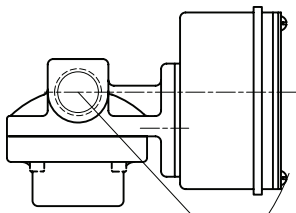

5.12[130mm] APPROX.  
SWING RADIUS

Maximum installation dimensions

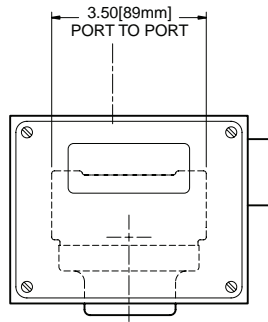

3.50[89mm]  
PORT TO PORT

### “R” Box



“R” box is selected for greater resolution (more increments on the inscribed scale).

It holds switches (general purpose and hazardous location all classes groups and divisions) and 4-20mA transmitter. Switch (standard service) and transmitter are offered in this control box together when signal redundancy is desired.

You get this control box when you order any CONTROL BOX & READOUT starting with an “R” (see "How to Order" page). Examples: R1WR is a one switch, weatherproof box with flow from left to right.

This control box is made from aluminum that is epoxy coated when ordered for weather proof and corrosion resistant (“X”).

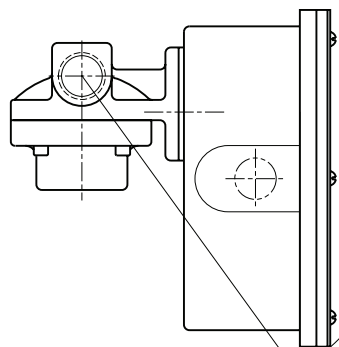

8.32[211mm] APPROX.  
SWING RADIUS

Maximum installation dimensions

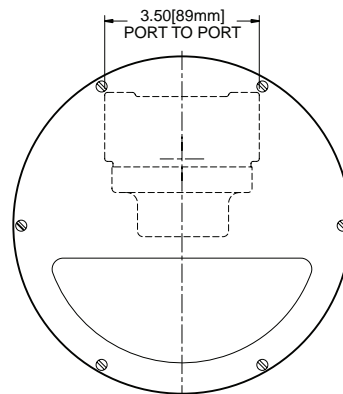

3.50[89mm]  
PORT TO PORT

# CONTROL BOX SELECTION GUIDE

## “T” Box



“T” box is selected for availability of two isolated junction boxes with terminal strips. This means that no direct wiring to switches or transmitters is required.

Digital LCD display of flow is optional (“TTL”).

It holds switches (general purpose) and 4-20mA transmitter. Switch (standard service) and transmitter are offered in this control box together when signal redundancy is desired. These are wired to separate junction boxes for signal isolation.

You get this control box when you order any CONTROL BOX & READOUT starting with a “T” (see "How to Order" page). Examples: TT1WR is a one switch with 4-20mA transmitter, weatherproof box with flow from left to right.

This control box is made from aluminum that is epoxy coated when ordered for weather proof and corrosion resistant (“X”).

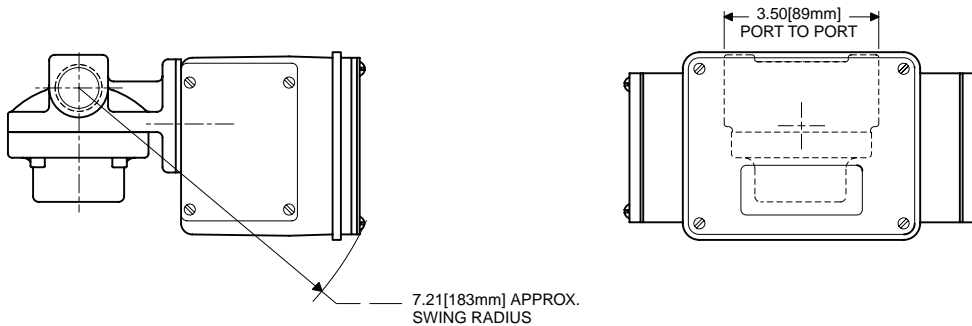

Maximum installation dimensions

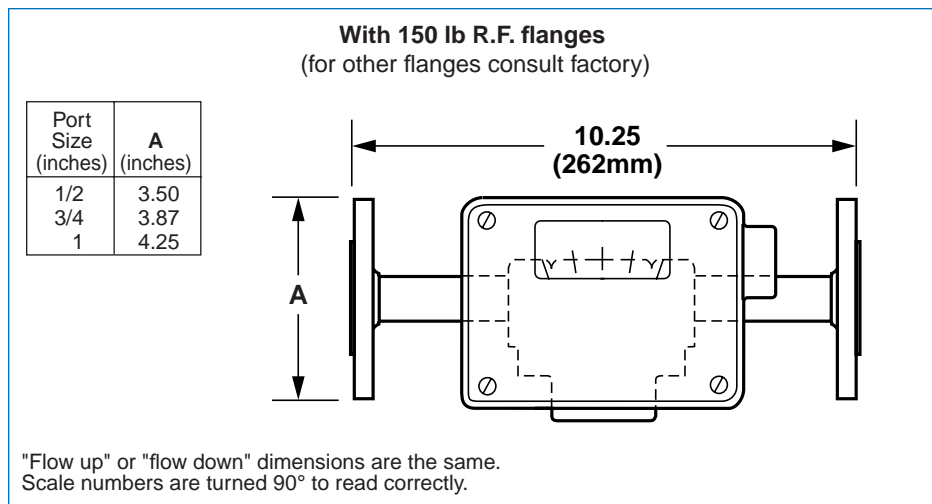

### Universal Flow Monitors, Inc.

1755 E. Nine Mile Road ▪ P.O. Box 249 ▪ Hazel Park, MI 48030  
Tel: 248-542-9635 ▪ Fax: 248-398-4274  
www.flowmeters.com ▪ E-mail: ufm@flowmeters.com