

Flow meters, Flow switches and Flow transmitters

A Medium Vane-Style For Corrosive Fluids

 CSA Certified NRTL/C

 CE Marked (as noted)

NIST Traceable Calibration
Certificate Available



*MX shown with "A"
style control box.*

DESCRIPTION

These variable-area flow meters have a spring-loaded swinging vane. Mounting is in-line and in any position. Straight pipe runs, before or after the meter, are not required. The all-mechanical sensing system directly drives the pointer and remote signaling devices.

CALIBRATION

All flow meters are individually calibrated for fluids with the viscosity you specify (up to 3000 SSU (650 Centistokes)). We compensate for your fluid's specific gravity. For NIST Traceability please consult factory.

OUTPUTS

The flowmeter has outputs both visual and electronic. Visual displays are either pointer (with inscribed scale) or numeric. Signal outputs can be mechanical switch closure, 4-20 mA analog or both (for signal redundancy). The switches can

be general purpose or rated for hazardous locations (all classes, groups and divisions). The 4-20 mA transmitters are Intrinsically Safe if used with approved barriers.

CONSTRUCTION MATERIALS

These flowmeters have plastic bodies, a wide variety of metal internals, and fittings. They are ideally suited to monitor flows of such fluids as corrosive liquids, seawater, deionized water, acids, caustics, and plating solutions. See selections in the "How to Order" section.

LINE CONNECTION

Threaded units have 2 ½ inch -12 SAE ports. Adapters are used to offer NPT female port connections in a variety of materials and sizes (see "How to Order" section). Van Stone flanges are offered in a variety of sizes in PVC.

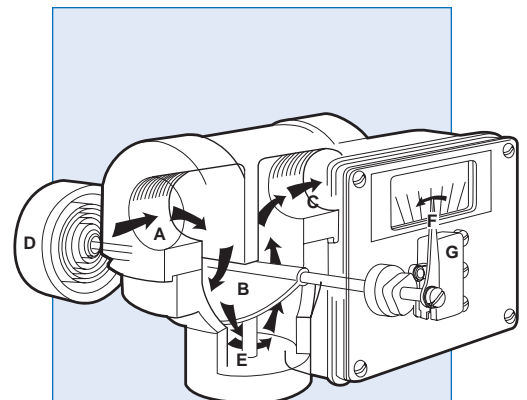

Fluid enters at **A**, passes around the semi-circular vane **B**, exits at outlet **C**. The vane resists the flow because of the spring **D**. The further the vane is pushed the larger the passageway **E** becomes. This minimizes the increase in pressure drop. The vane shaft turns to operate the pointer **F** and remote signal devices such as the switch **G**.

Viton® and Kalrez™ are registered trademarks for DuPont Performance Elastomers.

HOW TO ORDER Select appropriate symbols and build a model code number, as in example shown:

EXAMPLE: MX - V I F

70 GM -

12I -

32V1.0 -

SERIES	
Medium	= MX

HOUSING MATERIAL	
PVC	= V
Polysulfone	= P
Tefzel	= T

INTERNAL MOVING PARTS	
316 Stainless Steel	= I
Titanium	= T
Monel	= L
Hastelloy C	= C

SEAL MATERIAL	
Buna N	= B
EPR	= E
Viton	= F
Kalrez	= J
Kalrez (dynamic)/Buna N (static)	= A
Kalrez (dynamic)/EPR (static)	= H
Kalrez (dynamic)/Viton (static)	= K

MAX FLOW RATE LIQUIDS	
GPM	10, 15, 20, 30, 40, 50, 60, 70, 80, 90, 100, 110, 120, 130, 140, 150, 160 = GM
LPM	40, 50, 60, 70, 80, 90, 100, 150, 200, 250, 300, 350, 400, 500, 600 = LM
CMH	2.25, 2.5, 3, 4, 5, 6, 7, 8, 9, 10, 15, 20, 25, 30 = CMH

PORT CONNECTION			
	Inches	MM	Max GPM
VAN STONE PIPE FLANGE (PVC only)	1	25.40	70 = 8R
	1 1/2	38.10	100 = 12R
	2	50.80	160 = 16R
	2 1/2	63.50	160 = 20R
	3	76.20	160 = 24R
NPT (Female adapters)			
316 stainless steel	1	25.40	70 = 8I
	1 1/2	38.10	100 = 12I
Titanium	1	25.40	70 = 8T
	1 1/2	38.10	100 = 12T
Monel	1	25.40	70 = 8L
	1 1/2	38.10	100 = 12L
*PVC	1	25.40	70 = 8V
	1 1/2	38.10	100 = 12V
*Polysulfone	1	25.40	70 = 8P
	1 1/2	38.10	100 = 12P
Tefzel	1	25.40	70 = 8Z
	1 1/2	38.10	100 = 12Z

*Material will be same as housing;
Adapter O-ring will be same as static seal material.

FLUID CHARACTERISTICS
Viscosity number followed by a 'V' (for SSU), 'C' (for centipoise), or 'CS' (for centistokes) followed by the specific gravity. Example: **32V1.0** would indicate a fluid with a viscosity of 32 SSU with a specific gravity of 1.0 (water). For dual viscosities (where there is a start up viscosity or where there may be a range) put in both values with a slash. Example: 320/150V.9.

A3 W R - E - ST - 5D

SERVICE

Oil and dust tight (Type 12)	=	N
Weatherproof (Type 4)	=	W
Weatherproof, corrosion proof (Type 4X)	=	X

FLOW DIRECTION

Left to right	=	R
Right to left	=	L
Up	=	U
Down	=	D

SPECIAL OPTIONS

Stainless steel ID tag for customer supplied information	=	ST
Tempered glass window	=	TG
Manual override	=	E
Dual spring	=	DS
Clearance vane for ≥ 16 GPM	=	Z86

SWITCH SETTING

No symbol = Lowest possible setting (usually 10% of maximum flow)
 Desired set point is assumed to be in flow units already selected (GPM). Give flow rate followed by a "D" for flow going down (flow failure) or a "U" for flow going up.
 Example, 5D indicates a setting of 5 GPM in declining flow.

CONTROL BOX & READOUT

Basic Features ↓	Additional Options ↓	Standard resolution pointer and inscribed scale			High resolution pointer and inscribed scale	Separate junction boxes (with terminal strips) for switch & transmitter
		"A", "L" and "Z" Box			"R" Box	"T" Box
		Materials of Construction				
		Polysulfone	Aluminum	316 Stainless	Aluminum	Aluminum
These options all include inscribed scale and pointer plus one of the standard (non hazardous location) switches selected to the right.	No switch	A0	L0	Z0	R0	
	One SPDT (3 wire), CE	A1	L1	Z1	R1	
	One high vibration SPDT (3 wire), CE	A1B	L1B	Z1B		
	Two SPDT (3 wire), CE	A2	L2	Z2	R2	
	Two high vibration SPDT (3 wire), CE	A2B	L2B	Z2B		
	One SPDT (4 wire)	A3	L3	Z3	R3	
	Two SPDT (4 wire)	A4	L4	Z4	R4	
	One SPDT (3 wire) gold contact	A71	L71	Z71	R71	
	Two SPDT (3 wire) gold contact	A72	L72	Z72	R72	
These options all contain inscribed scale with pointer plus hazardous location switches selected to the right. Note that the box is not rated, only the switches.	One SPDT hazardous location (all classes, groups and divisions)				R7	
	One DPDT hazardous location (all classes, groups and divisions)				R17	
	Two SPDT hazardous location (all classes, groups and divisions)				R18	
	Two DPDT hazardous location (all classes, groups and divisions)				R19	
	One SPST hazardous location proximity (all classes, groups and divisions)				R30	
	Two SPST hazardous location proximity (all classes, groups and divisions)				R31	
	One SPDT (3 wire) hermetically sealed	A53	L53	Z53		
Two SPDT (3 wire) hermetically sealed	A54	L54	Z54			
These options all contain a 4-20 mA transmitter and one of the selections to the right.	No switches (Intrinsic safe with barrier)	AX0	LX0	ZX0	RX0	TT0
	One SPDT (3 wire), CE				RX1	TT1
	Two SPDT (3 wire) CE rated switches					TT2
	One SPDT (4 wire)				RX3	TT3
	One SPDT (3 wire) hermetically sealed					TT53
These options all include a 4-20 mA transmitter with a digital LCD display plus one of the selections to the right.	No switches					TTL0
	One SPDT (3 wire), CE					TTL1
	One SPDT (4 wire)					TTL3

ENGINEERING DATA

Maximum operating temperature:

PVC housing: 100°F (38°C)
 Polysulfone housing: 200°F (95°C)
 Tefzel housing: 200°F (95°C)

Maximum ambient temperature:

130°F (UL listed to 105°F (40°C; for hazardous locations -13 to +104°F)

Maximum operating pressures:(3:1 safety factor)

PVC housing: 100 PSI (6.90 BAR)
 Polysulfone housing: 200 PSI (13.79 BAR)
 Tefzel housing: 150 PSI (10.3 BAR)

Readout accuracy, full scale: ±2%

Switch repeatability is 1% of actual flow rate.

FLOW & PRESSURE DROP

Units with max flows to 80 GPM (300 LPM) impose a pressure drop that increases with flow, from 1.9 to 3.8 PSI. Higher flow-rated models are made possible by having a partial bypass (which raises minimum indicated flow), or dual springs (which raises the pressure drop). The table shows minimum flow rates and pressure drops (PSI) (at max flow rates) for models rated from 100 to 160 GPM.

MAX FLOW RATE GPM/LPM	BYPASS ONLY		DUAL SPRING*	
	Minimum Flow GPM/LPM	Max Pressure Drop PSI	Minimum Flow GPM/LPM	Max Pressure Drop PSI
90/340	20/75	4.5	10/40	6.0
100/380	30/100	4.5	10/50	8.0
110/400	30/100	5.0	20/90	6.8
120/450	40/150	5.8	20/90	6.8
130/500	40/150	5.8	20/90	6.8
140/550	50/190	6.5	20/90	6.8
150/570	50/190	6.5	30/100	6.8
160/600	50/190	6.5	30/100	7.5

*When dual-spring is ordered you must specify special option **DS**. Some dual-spring units also have partial bypass to achieve high flow ranges.

SPECIAL OPTIONS

Identification tag: (option **ST**) customer-supplied information is stamped on a stainless steel tag that is attached to the nameplate.

Multi-pin connector: Pin connectors (option **PC**) are available for rapid field installation. Meters are provided with the male half of either a micro or a mini pin connector. Check the chart below for the number of pins required for your control box selection and current type. Insert the number of pins in the code PC__ for a mini connector or PC__M for a micro connector. For example, a PC5 would be a 5 pin mini and PC5M would be a 5 pin Micro.

Tempered-glass window: (option **TG**) replaces the standard window. A tempered-glass window is employed where airborne solvents or high-ambient temperatures are common.

Manual override: (option **E**) provides an extended shaft you can manipulate to clear debris, simulate flow, adjust switch settings, etc. Same material as internals specified.

Clearance vane: (option **Z86**) the swing vane is modified to provide extra clearance for liquids that contain particulate. Available for maximum flow range of 16 GPM or greater, this reduces the turndown to a minimum of 4 GPM.

Number of pins required for various combinations of current type, box type and switch option.

Box	AC switch options			1, 1B, 61, 71		3		53
	DC switch options	0	1, 1B, 61, 71	3	2, 2B, 54, 62, 72		53	
A			3	4	6	5	3	4
R			3	4	6	5	3	4
RT	3							
TT	3	3		4			3	4
TTL	3	3		4			3	4

*This box allows micro pin connectors only. Eg. PC3M or PC5M.

CONTROL BOX SELECTION GUIDE

“A” Box

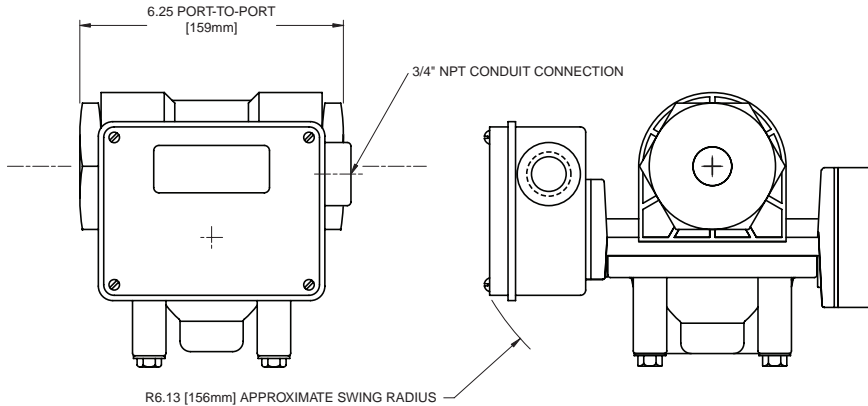

Maximum installation dimensions

“A” box is selected for price and simplicity.

It holds switches (general purpose and hermetically sealed) or 4-20mA transmitter.

You get this control box when you order any CONTROL BOX & READOUT starting with an “A” (see "How to Order" page). Examples: A1WR is a one switch, weatherproof box with flow from left to right.

This control box is made of Polysulfone (standard low cost “A”) with options for aluminum (“L”) or 316 stainless steel (“Z”).

“R” Box

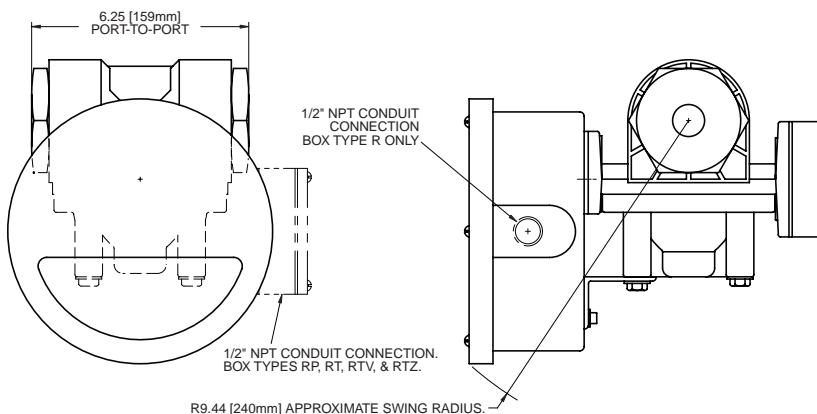

Maximum installation dimensions

“R” box is selected for greater resolution (more increments on the inscribed scale).

It holds switches (general purpose and hazardous location all classes groups and divisions) and 4-20mA transmitter. Switch (standard service) and transmitter are offered in this control box together when signal redundancy is desired.

You get this control box when you order any CONTROL BOX & READOUT starting with an “R” (see "How to Order" page). Examples: R1WR is a one switch, weatherproof box with flow from left to right.

This control box is made from aluminum that is epoxy coated when ordered for weather proof and corrosion resistant (“X”).

CONTROL BOX SELECTION GUIDE

“T” Box



“T” box is selected for availability of two isolated junction boxes with terminal strips. This means that no direct wiring to switches or transmitters is required.

Digital LCD display of flow is optional (“TTL”).

It holds switches (general purpose) and 4-20mA transmitter. Switch (standard service) and transmitter are offered in this control box together when signal redundancy is desired. These are wired to separate junction boxes for signal isolation.

You get this control box when you order any CONTROL BOX & READOUT starting with a “T” (see "How to Order" page). Examples: TT1WR is a one switch with 4-20mA transmitter, weatherproof box with flow from left to right.

This control box is made from aluminum that is epoxy coated when ordered for weather proof and corrosion resistant (“X”).

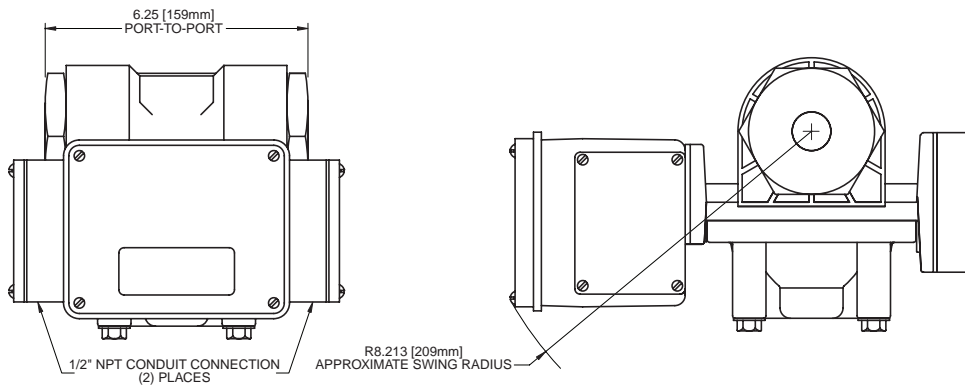

Maximum installation dimensions

Vanstone Flanges (PVC units only)

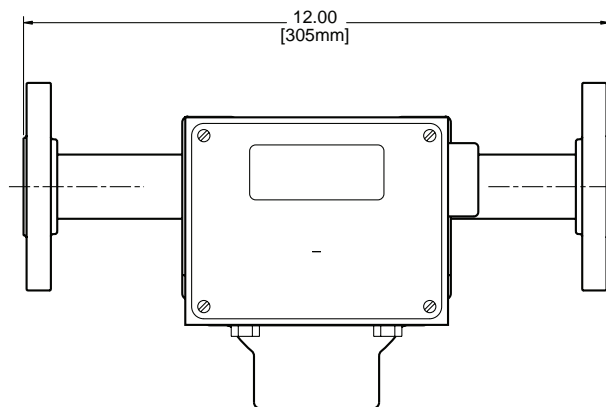

“Flow up” or “Flow down” dimensions are the same. Scale numbers are turned 90° to be right reading.



Universal Flow Monitors, Inc.

1755 E. Nine Mile Road ▪ P.O. Box 249 ▪ Hazel Park, MI 48030

Tel: 248-542-9635 ▪ Fax: 248-398-4274

www.flowmeters.com ▪ E-mail: ufm@flowmeters.com