

INSERTION Adaptor for analysis



Type S022 can be combined with...



Type 8202

pH or O.R.P. transmitter



Type 8222

Resistive conductivity transmitter

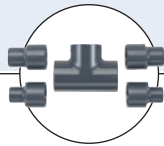

Pipe and fitting



Saddle



Bürkert fitting

Body (for conversion)

The adaptor is used to connect the compact analytical ELEMENT transmitters into piping systems.

Different versions of adaptors are available:

- PVC-U adaptor to stick into equal or reduced standard metric or ASTM Tee fitting
- PP adaptor to weld into equal d32 standard metric Tee fitting
- Stainless steel adaptor to weld
- PVC threaded adaptor to screw on tank or pipe
- PVC, PP, stainless steel adaptor for conversion of S020 Bürkert fitting into S022 fitting.

- Universal adaptor for type 8202 and 8222 ELEMENT transmitters in pure, aggressive or contaminated liquids
- Adaptation into standard piping systems or conversion of Bürkert S020 fittings into S022 fittings
- Pipe diameters from DN 06 (with reduction) up to DN 110 (plastic) or bigger (Stainless steel)

General data

Pipe diameter	DN 06 (with reduction) up to DN 110 (plastic) or bigger (metal)
Adaptor connection	Solvent, fusion, welding, threaded and to connect with screws
Materials	PVC, PP, stainless steel - delivered with 2 gaskets, 1 FKM and EPDM

Medium data

Fluid temperature	See pressure-temperature chart on next page. Temperature limits may depend on the transmitter. Please refer to appropriate instruction manual or data sheet for more details.
Fluid pressure (max.)	PN 10 (plastic) or PN16 (metal) Pressure limits may depend on the transmitter. Please refer to appropriate instruction manual or data sheet for more details.

Environment - Approvals

Ambient temperature	Temperature limits may depend on the sensor. Please refer to appropriate instruction manual or data sheet for more details.
----------------------------	---

INDUSTRIAL DYNAMICS CO

1-800-940-0453



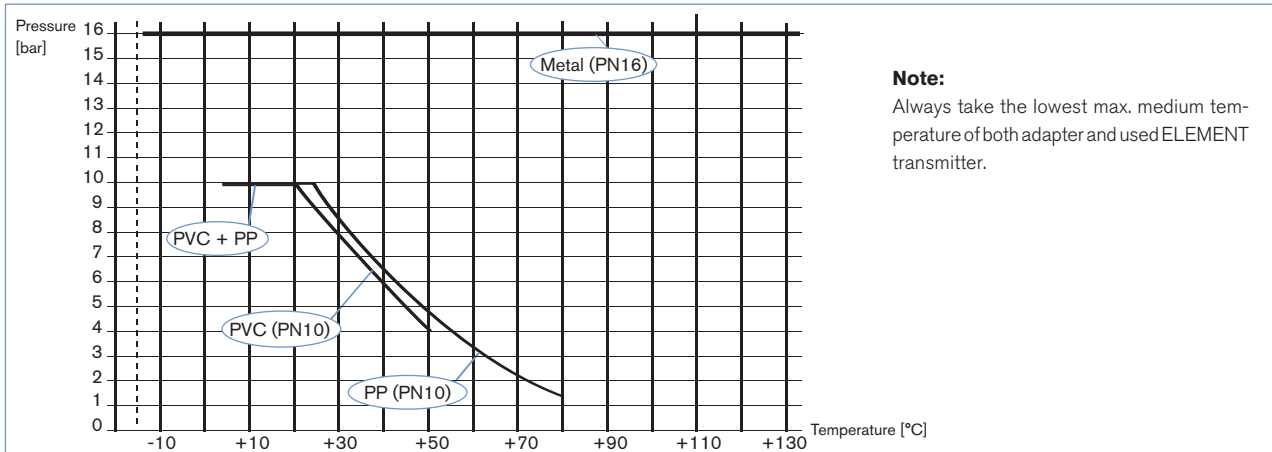







Pressure / temperature chart

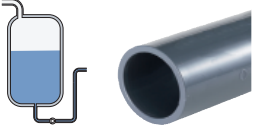

Note:

Always take the lowest max. medium temperature of both adapter and used ELEMENT transmitter.

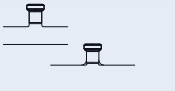
Adaptation overview

Adaptor S022	 PVC-U, PP metric or ASTM	 Stainless steel	 PVC-U, G or NPT 1/4" screw-on	 PVC-U, PP, stainless steel for Bürkert fitting body
Piping systems				
Final products				
DN	32 up to 110 (06 up to 25 with reduction)	Respect recommendations of installation	Respect recommendations of installation	32 up to 50

Installation and recommendations

For pH and ORP measurements, we recommend a "U"- form bypass installation to ensure that the electrode is maintained in a wet condition and enable the customer to calibrate the unit without stopping the whole process. Pressure and temperature ratings must be respected according to the selected adaptor material. Be sure that the sensor finger is completely covered with liquid. Avoid dead legs which interfere the local fluid exchange.

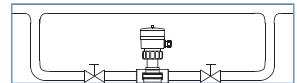

When mounting the adaptor into a Tee fitting, a tank or directly into a pipe, please ensure that the minimum immersion depth of the electrode from transmitter you use is respected (Refer to the under drawing).

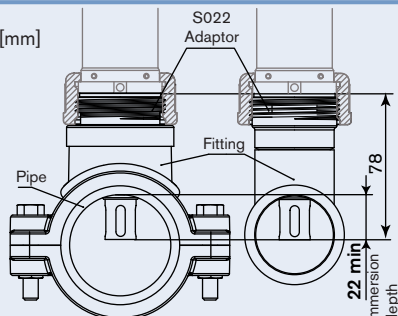
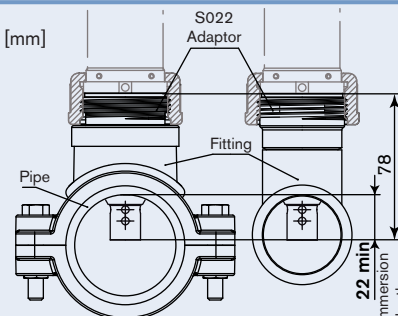
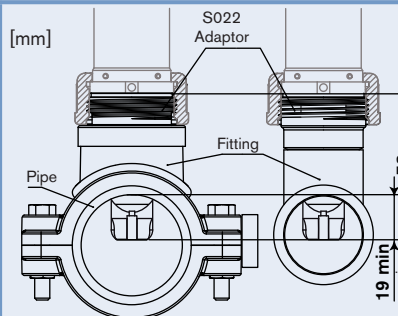



S022 used with 8202 pH transmitter	S022 used with 8222 conductivity transmitter C = 0.01 or 0.1	S022 used with 8222 conductivity transmitter C = 1
		

Ordering chart and dimensions for INSERTION adaptor S022

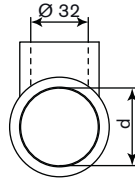
For connection into Tee fitting or pipe

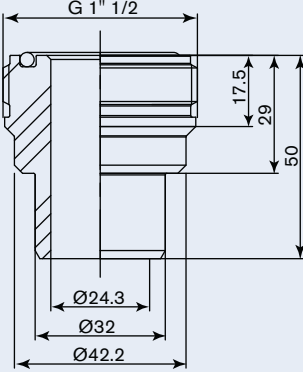

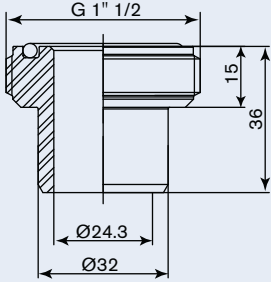
Note: Tee fitting to use for mounting the S022, shown in the opposite drawing

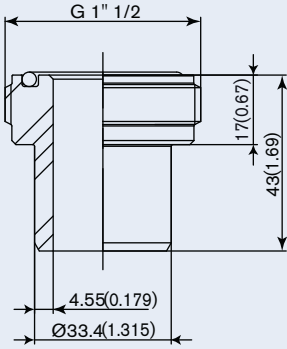

	Description	Materials Body / Seal ¹⁾	Type of installation	Dimensions	Item no.
	Metric solvent adaptor with G 1/2" external threaded for ELEMENT transmitter connection	PVC-U / FKM, EPDM	To stick on d32x32 or d40x32 Tee fitting with solvent socket		560 705
	Metric solvent adaptor with G 1/2" external threaded for ELEMENT transmitter connection	PVC-U / FKM, EPDM	To stick on d50x32 up to d50-110x32 Tee fitting with solvent socket		560 706
	ASTM solvent adaptor with G 1/2" external threaded for ELEMENT transmitter connection	PVC-U / FKM, EPDM	To stick on 1"x1" up to 3"x1" Tee fitting with solvent socket		561 227

¹⁾ 1 FKM and 1 EPDM gaskets for the transmitter connection are supplied with each adaptor.

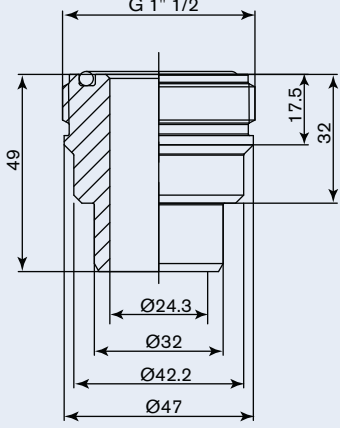

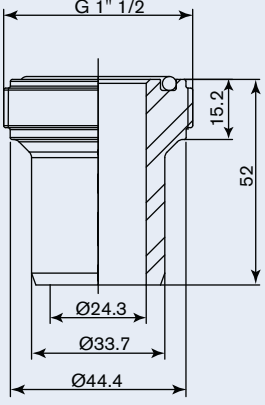
Ordering chart and dimensions for INSERTION adaptor S022 (continued)

	Description	Materials Body / Seal ¹⁾	Type of installation	Dimensions	Item no.
	Metric fusion adaptor with G 1 1/2" external threaded for ELEMENT transmitter connection	PP / FKM, EPDM	To weld on d32x32 Tee fitting with fusion socket	 <p>Technical drawing showing dimensions for the metric fusion adaptor: G 1" 1/2, 49, 17.5, 32, Ø24.3, Ø32, Ø42.2, Ø47.</p>	561 229
	Metric welding adaptor Ø33.7 with G 1 1/2" external threaded for ELEMENT transmitter connection	Stainless steel / FKM, EPDM	To weld directly on pipe	 <p>Technical drawing showing dimensions for the metric welding adaptor: G 1" 1/2, 15.2, 52, Ø24.3, Ø33.7, Ø44.4.</p>	561 232

¹⁾ 1 FKM and 1 EPDM gaskets for the transmitter connection are supplied with each adaptor.

Ordering chart and dimensions for INSERTION adaptor S022 (continued)

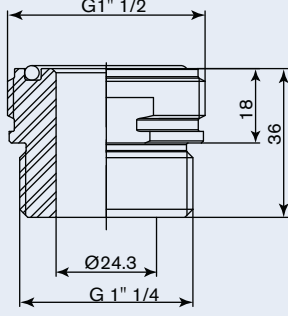
For connection on tank or pipe

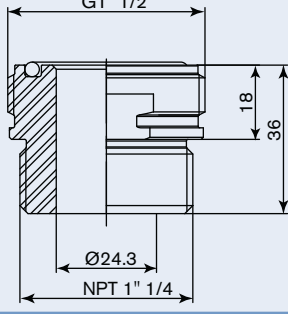
	Description	Materials Body / Seal ¹⁾	Type of installation	Dimensions	Item no.
	G1 1/4" screw-on adaptor with G 1 1/2" external threaded for ELEMENT transmitter connection	PVC-U / FKM, EPDM	To screw on tank or pipe		560 707
	NPT 1 1/4" screw-on adaptor with G 1 1/2" external threaded for ELEMENT transmitter connection	PVC-U / FKM, EPDM	To screw on tank or pipe		561 228

¹⁾ 1 FKM and 1 EPDM gaskets for the transmitter connection are supplied with each adaptor.

i Further versions on request







Materials

PVC-C, PVDF with FKM or EPDM gasket

Ordering chart - accessories for adaptor S022 (has to be ordered separately)

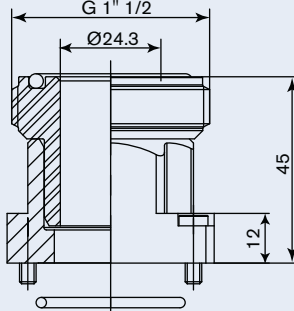
Specifications	Item no.
Stopper in stainless steel with union nut and O-ring (EPDM and FKM)	562 625
Stopper in PVC with union nut and O-ring (EPDM and FKM)	562 541

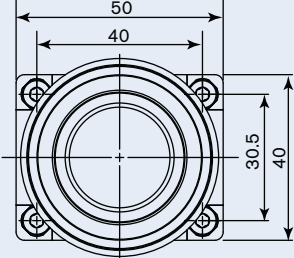
Ordering chart and dimensions for adaptor to convert S020 Tee fitting into S022

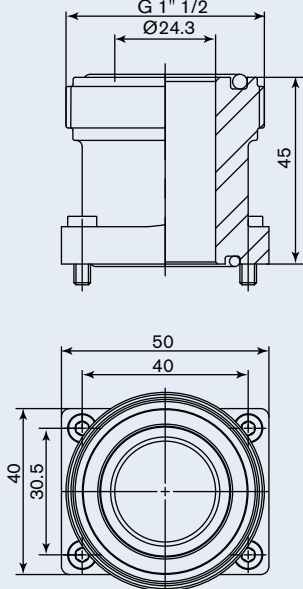
	Description	Materials Body / Seal ¹⁾²⁾	Type of installation	Dimensions	Item no.
	Adaptor with G 1 1/2" external threaded for ELEMENT transmitter connection	PVC-U / FKM, EPDM	For Bürkert fitting body - DN32 or bigger		560 854
	Adaptor with G 1 1/2" external threaded for ELEMENT transmitter connection	PP / FKM, EPDM	For Bürkert fitting body - DN32 or bigger		561 230
	Adaptor with G 1 1/2" external threaded for ELEMENT transmitter connection	Stainless steel / FKM, EPDM	For Bürkert fitting body - DN32 or bigger		561 233

1) 1 FKM and 1 EPDM gaskets for the transmitter connection are supplied with each adaptor.
 2) 1 FKM and 1 EPDM gaskets for the fitting body connection are supplied with each adaptor.

INDUSTRIAL DYNAMICS CO

1-800-940-0453

In case of special application conditions, please consult for advice.

Subject to alteration.
 © Christian Bürkert GmbH & Co. KG

1107/2_EU-en_00895118